



---

*User Guide*

---

**DCX3510-M**

**High-Definition All-Digital Dual  
Tuner DVR Set-top**

©ARRIS Enterprises, Inc. 2014 All rights reserved. No part of this publication may be reproduced in any form or by any means or used to make any derivative work (such as translation, transformation, or adaptation) without written permission from ARRIS Enterprises, Inc. ("ARRIS"). ARRIS reserves the right to revise this publication and to make changes in content from time to time without obligation on the part of ARRIS to provide notification of such revision or change.

ARRIS and the ARRIS logo are all trademarks of ARRIS Enterprises, Inc. Other trademarks and trade names may be used in this document to refer to either the entities claiming the marks and the names of their products. ARRIS disclaims proprietary interest in the marks and names of others.

ARRIS provides this guide without warranty of any kind, implied or expressed, including, but not limited to, the implied warranties of merchantability and fitness for a particular purpose. ARRIS may make improvements or changes in the product(s) described in this manual at any time.

The capabilities, system requirements and/or compatibility with third-party products described herein are subject to change without notice.



# Safety & Regulatory Information

## IMPORTANT SAFETY INSTRUCTIONS

- Read these instructions.
- Keep these instructions.
- Heed all warnings.
- Follow all instructions.
- Do not use this apparatus near water.
- Clean only with dry cloth.
- Do not block any ventilation openings. Install in accordance with the manufacturer's instructions.
- Do not install near any heat sources such as radiators, heat registers, stoves, or other apparatus (including amplifiers) that produce heat.
- Do not defeat the safety purpose of the polarized or grounding type plug. A polarized plug has two blades with one wider than the other. A grounding type plug has two blades and a third grounding prong. The wide blade or the third prong is provided for your safety. If the provided plug does not fit into your outlet, consult an electrician for replacement of the obsolete outlet.
- Protect the power cord from being walked on or pinched particularly at plugs, convenience receptacles, and the point where they exit from the apparatus.
- Only use attachments/accessories specified by the manufacturer.
- Unplug this apparatus during lightning storms or when unused for long periods of time.
- Refer all servicing to qualified service personnel. Servicing is required when the apparatus has been damaged in any way, such as the power supply cord or plug is damaged, liquid has been spilled or objects have fallen into the apparatus, the apparatus has been exposed to rain or moisture, does not operate normally, or has been dropped.

## IMPORTANT SAFETY CONSIDERATIONS

The DCX3510-M set-top requires careful handling to avoid potential damage to its internal hard disk drive or the loss of recorded data. Be sure to follow these requirements during transportation and installation.

The plug is the main disconnect device. It shall remain readily accessible and operable.

The apparatus shall not be exposed to dripping or splashing and no objects filled with liquids, such as vases, shall be placed on the apparatus.

### During Transportation to the Subscriber Home

Transport the cable terminal in its shipping box or an equally padded container.

Do not expose the terminal to rain or moisture.

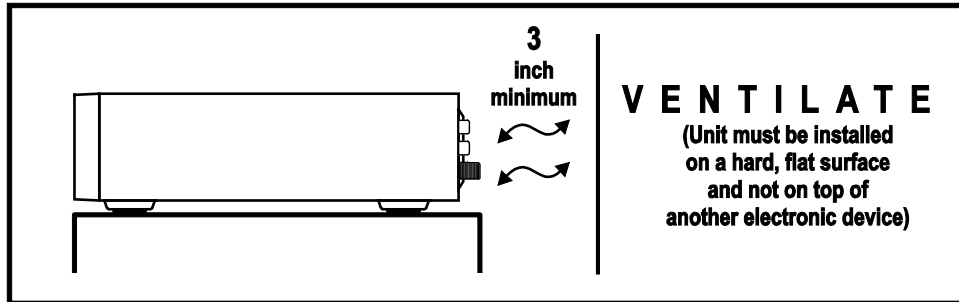

### During Installation

- Do not place the terminal in an enclosed area where the cooling vents are blocked or impede the flow of air through the ventilation openings.
- Install the terminal so that its position does not interfere with its proper ventilation. For example, do not place the terminal on a bed, sofa, rug, or similar surface that could block the ventilation openings.
- Install the terminal away from heat sources such as radiators, heat registers and stoves. Installation of the terminal near consumer electronics devices, such as stereo receiver/amplifiers and televisions, is permitted as long as the air surrounding the terminal does not exceed 40° C (104° F).
- Place the terminal on a flat surface not prone to vibration or impact.
- Do not install the terminal in an area where condensation occurs.
- To prevent the temporary loss of guide data and cause a temporarily non-responding terminal, do not plug the AC power cord into a switched power outlet.
- To avoid shock and vibration damage to the internal hard drive, do not move the terminal while it is plugged in.
- To allow the hard drive to spin down and park its heads, wait at least 10 seconds after disconnecting power before moving the terminal.

### FCC Compliance

Note: This equipment has been tested and found to comply with the limits for a Class B digital device, pursuant to part 15 of the FCC Rules. These limits are designed to provide reasonable protection against harmful interference in a residential installation. This equipment uses and can radiate radio frequency energy and, if not installed and used in accordance with the instructions, may cause harmful interference to radio communications. However, there is no guarantee that interference will not occur in a particular installation. If this equipment does cause harmful interference to radio or television reception, which can be determined by turning the equipment off and on, the user is encouraged to try to correct the interference by one or more of the following measures:

- Reorient or relocate the receiving antenna.
- Increase the separation between the equipment and set-top.
- Connect the equipment into an outlet on a circuit different from that to which the set-top is connected.
- Consult the dealer or an experienced radio/TV technician for help.

Caution: Changes or modifications not expressly approved by ARRIS for compliance could void the user's authority to operate the equipment.

This device complies with part 15 of the FCC Rules. Operation is subject to the following two conditions: (1) This device may not cause harmful interference, and (2) this device must accept any interference received, including interference that may cause undesired operation.

### **FCC Declaration Of Conformity**

ARRIS Enterprises, Inc. 3871 Lakefield Drive, Suwanee, GA 30024, 1-215-323-1000, declares that the DCX3510-M set-top complies with 47 CFR Parts 2 and 15 of the FCC rules as a Class B digital device.

### **Canada Industry Canada (IC)**

This Class B digital device complies with Canadian ICES-003.

Cet appareil numérique de la classe B est conforme à la norme NMB-003 du Canada.

## **Caring for the Environment by Recycling**

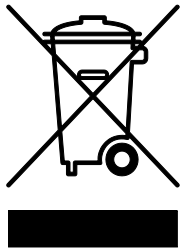

When you see this symbol on a ARRIS product, do not dispose of the product with residential or commercial waste.

#### **Recycling your ARRIS Equipment**

Please do not dispose of this product with your residential or commercial waste. Some countries or regions, such as the European Union, have set up systems to collect and recycle electrical and electronic waste items. Contact your local authorities for information about practices established for your region..



# Software License

IMPORTANT: PLEASE READ THIS SOFTWARE LICENSE (“LICENSE”) CAREFULLY BEFORE YOU USE ANY SOFTWARE, FIRMWARE AND RELATED DOCUMENTATION (“SOFTWARE”) PROVIDED WITH THE ARRIS DIGITAL CABLE RECEIVER OR HOME THEATER SYSTEM (EACH SHALL BE REFERRED TO IN THIS LICENSE AS A “RECEIVER”). BY USING THE RECEIVER AND/OR USING ANY OF THE SOFTWARE, YOU INDICATE YOUR ACCEPTANCE OF EACH OF THE TERMS OF THIS LICENSE. UPON ACCEPTANCE, THIS LICENSE WILL BE A LEGALLY BINDING AGREEMENT BETWEEN YOU AND ARRIS. THE TERMS OF THIS LICENSE APPLY TO YOU AND TO ANY SUBSEQUENT USER OF THIS SOFTWARE.

IF YOU DO NOT AGREE TO ALL OF THE TERMS OF THIS LICENSE (I) DO NOT USE THE SOFTWARE AND (II) RETURN THE RECEIVER AND THE SOFTWARE (COLLECTIVELY, “PRODUCT”), INCLUDING ALL COMPONENTS, DOCUMENTATION AND ANY OTHER MATERIALS PROVIDED WITH THE PRODUCT, TO YOUR POINT OF PURCHASE OR SERVICE PROVIDER, AS THE CASE MAY BE, FOR A FULL REFUND.

The Software includes associated media, any printed materials, and any “on line” or electronic documentation. Software provided by third parties may be subject to separate end user license agreements from the manufacturers of such Software. The Software is never sold. ARRIS licenses the Software to the original customer and to any subsequent licensee for personal use only on the terms of this License. ARRIS and its third party licensors retain the ownership of the Software.

You may:

USE the Software only in connection with the operation of the Product.

TRANSFER the Software (including all component parts and printed materials) permanently to another person, but only if the person agrees to accept all of the terms of this License. If you transfer the Software, you must at the same time transfer the Product and all copies of the Software (if applicable) to the same person or destroy any copies not transferred.

TERMINATE this License by destroying the original and all copies of the Software (if applicable) in whatever form.

You may not:

(1) Loan, distribute, rent, lease, give, sublicense or otherwise transfer the Software, in whole or in part, to any other person, except as permitted under the TRANSFER paragraph above. (2) Copy or translate the User Guide included with the Software, other than for personal use. (3) Copy, alter, translate, decompile, disassemble or reverse engineer the Software, including but not limited to, modifying the Software to make it operate on non compatible hardware. (4) Remove, alter or cause not to be displayed, any copyright notices or startup message contained in the Software programs or documentation. (5) Export the Software or the Product components in violation of any United States export laws.

The Product is not designed or intended for use in on line control of aircraft, air traffic, aircraft navigation or aircraft communications; or in design, construction, operation or maintenance of any nuclear facility. ARRIS AND ITS THIRD PARTY LICENSORS DISCLAIM ANY EXPRESS OR IMPLIED WARRANTY OF FITNESS FOR SUCH USES. YOU REPRESENT AND WARRANT THAT YOU SHALL NOT USE THE PRODUCT FOR SUCH PURPOSES.

Title to this Software, including the ownership of all copyrights, mask work rights, patents, trademarks and all other intellectual property rights subsisting in the foregoing, and all adaptations to and modifications of the foregoing shall at all times remain with ARRIS and its third party licensors. ARRIS retains all rights not expressly licensed under this License. The Software, including any images, graphics,

photographs, animation, video, audio, music and text incorporated therein is owned by ARRIS or its third party licensors and is protected by United States copyright laws and international treaty provisions. Except as otherwise expressly provided in this License, the copying, reproduction, distribution or preparation of derivative works of the Software, any portion of the Product or the documentation is strictly prohibited by such laws and treaty provisions. Nothing in this License constitutes a waiver of the ARRIS rights under United States copyright law.

This License and your rights regarding any matter it addresses are governed by the laws of the Commonwealth of Pennsylvania, without reference to conflict of laws principles. THIS LICENSE SHALL TERMINATE AUTOMATICALLY if you fail to comply with the terms of this License.

ARRIS is not responsible for any third party software that is provided as a bundled application, or otherwise, with the Software or that is downloaded to, or otherwise installed on, the Product.

#### U.S. GOVERNMENT RESTRICTED RIGHTS

The Product and documentation is provided with RESTRICTED RIGHTS. The use, duplication or disclosure by the Government is subject to restrictions as set forth in subdivision (c)(1)(ii) of The Rights in Technical Data and Computer Software clause at 52.227 7013. The contractor/manufacturer is ARRIS Enterprises, Inc. 3871 Lakefield Drive, Suwanee, GA 30024.

# Contents

<b>Safety &amp; Regulatory Information</b> .....	<b>iii</b>
<b>Software License</b> .....	<b>vi</b>
<b>Tables</b> .....	<b>ix</b>
<b>Figures</b> .....	<b>ix</b>
<b>Introduction</b> .....	<b>1</b>
Overview.....	1
Features .....	1
Front Panel .....	2
Rear Panel.....	3
<b>Operation</b> .....	<b>4</b>
Turning Power On and Off .....	4
Changing Channels .....	4
Adjusting the Volume .....	4
Interactive Program Guide .....	4
Video Format Indicators (Front Panel Display) .....	5
M-Card™ .....	5
<b>Digital Video Recorder (DVR)</b> .....	<b>6</b>
Using the External DVR Expansion Feature.....	7
<b>Connecting Your DCX Set-top</b> .....	<b>8</b>
Video Connection Options .....	8
HDMI or IEEE-1394 — HDTV and SDTV .....	8
Component Video (YPbPr) — HDTV and SDTV.....	9
Composite Video — SDTV .....	9
Connecting an HDTV — Single Connection for Video/Audio.....	10
Cable In .....	10
HDMI.....	10
IEEE-1394.....	10
Connecting an HDTV — Separate Video/Audio Connections .....	12
Cable In .....	12
DVI .....	12
Component Video (YPbPr).....	12
Audio .....	12
Connecting an A/V Receiver — Audio.....	14
Connecting an SDTV .....	16
Connecting a Standard-Definition TV (SDTV) and VCR/DVD Recorder.....	17



Connecting an A/V Receiver, SDTV, and VCR/DVD Recorder .....	19
Connecting Your Set-top to an External eSATA DVR .....	21
Data Devices .....	22
Data Features .....	22
On-Screen Graphics .....	23
<b>Recording Your Connections .....</b>	<b>24</b>
<b>Configuring the User Settings .....</b>	<b>25</b>
User Settings Menu Main Screen .....	26
Native Mode Settings Screen .....	31
Additional HDMI Settings Screen .....	34
Additional Closed Caption Settings Screen .....	37
Subtitle and DVS Settings Screen .....	39
Advanced Audio/Video Settings Screen .....	40
<b>Troubleshooting .....</b>	<b>43</b>

## Tables

Table 1: User Settings Main Menu Field Descriptions .....	28
Table 2: Native Mode Settings Field Definitions .....	32
Table 3: Additional HDMI Settings Field Definitions .....	35
Table 4: Additional Closed Caption Settings Field Definitions .....	38
Table 5: Subtitle and DVS Settings Field Definitions .....	40
Table 6: Advanced Audio/Video Settings Field Definitions .....	42

## Figures

Figure 1: Front Panel .....	2
Figure 2: Rear Panel .....	3
Figure 3: Connecting an HDTV — Single Connection for Video/Audio .....	11
Figure 4: Connecting an HDTV — Separate Video/Audio Connections .....	13
Figure 5: Connecting an A/V Receiver — Audio .....	15
Figure 6: Connecting an SDTV .....	16
Figure 7: Connecting a Standard-Definition TV (SDTV) and VCR/DVD Recorder .....	18
Figure 8: Connecting an A/V Receiver, SDTV, and VCR/DVD Recorder .....	20
Figure 9: Connecting Your Set-top to an External eSATA DVR .....	21
Figure 10: Data Device Connections .....	22
Figure 11: Default User Settings Menu when no HDMI connection is in place .....	26
Figure 12: Default User Settings Menu when an HDMI connection is in place .....	27
Figure 13: User Settings Menu—Main Menu Screen .....	28

---

Figure 14: Native Mode Settings menu screen.....	32
Figure 15: Additional HDMI Settings screen .....	34
Figure 16: Additional Closed Caption Settings menu screen .....	37
Figure 17: Subtitle and DVS Settings Menu Screen .....	39
Figure 18: Advanced Audio/Video Settings Menu Screen.....	41

# 1

# Introduction

## Overview

Congratulations on receiving an ARRIS DCX3510-M Series High-Definition All-Digital Dual Tuner Cable Set-top, one of the most advanced interactive digital cable set-tops available today. ARRIS has merged the extraordinary features of digital cable — the seemingly endless programming options, interactive program guides, Video on Demand (VOD), and commercial-free, CD quality music — with the flexibility of a dual tuner-digital video recorder (DVR) and the incredible picture quality and sound of High-Definition TV (HDTV).

The DCX3510-M includes an “Entertainment Package” that enables a direct digital connection to consumer audio and video devices through IEEE-1394 and HDMI™ interfaces. Dolby® Digital Plus is supported by the HDMI interface and provides 7.1 channels and beyond of enhanced-quality audio. The set-top is fully equipped with a factory-installed hard drive for hours of DVR functionality, which includes the capability of recording two High-Definition programs, or watching one while recording another.

This User Guide introduces you to the basic features, outlines important safeguards, and provides several options for integrating this component into your current entertainment system. Please take a few moments to read through this User Guide; the configuration diagrams, on-screen menu description and troubleshooting sections will help you make the most of your home entertainment experience.

To determine which features of digital cable are provided in your service area, please check with your local cable operator. They will be happy to provide instructions for these optional services.

## Features

- All-Digital Dual Tuner High-Definition DVR M-Card Host (dual tuners support watch and record mode)
- Advanced A/V High-Definition decode
- Integrated MoCA™ networking
- HDMI, Component, IEEE-1394, Composite, Digital Audio (S/PDIF), Audio L/R, Ethernet, USB, eSATA
- 1080p 24/30 video decode and 1080p 24/30/60 video output support

## Front Panel



**Figure 1: Front Panel**

Number	Description
1	Power — Turns the set-top on and off (standby)

## Rear Panel

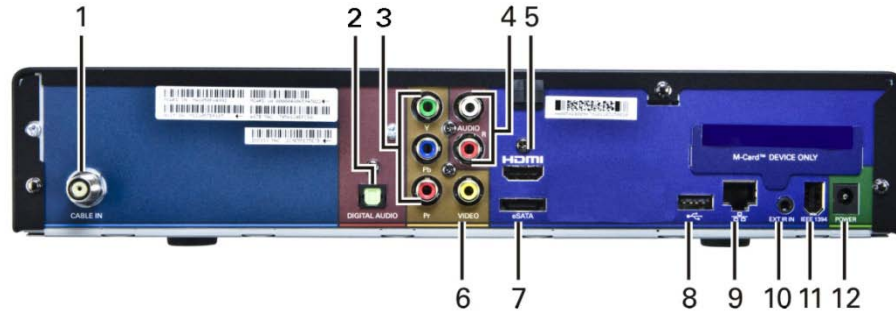

**Figure 2: Rear Panel**

Number	Description
1	Cable In — Connects to cable signal from your service provider
2	Digital Audio (Optical S/PDIF) — Provides Dolby® Digital or PCM output
3	Video outputs / YPbPr — Component video output (HDTV)
4	Audio Out — L/R audio
5	HDMI — High-Definition TV (HDTV) connector
6	Video Out — Composite Video (SDTV)
7	eSATA* — External Serial Advanced Technology Attachment disk interface
8	USB* 2.0 — High-Speed peripheral device connection
9	Ethernet* — Network connection
10	External IR Input — Connects to a remote control set-top accessory cable Data test connector (service personnel only)
11	IEEE-1394 — Audio and video device connection
12	Power connector

*\* Availability of certain features is dependent upon application support.*

# 2

## Operation

### Turning Power On and Off

Press power on the front panel or remote control to turn the DCX set-top on or off (standby). When using the remote control, be sure it is in cable mode by pressing cable before pressing power.

### Changing Channels

You can change channels in three ways:

- Press channel + or – on the remote control to step through the channel selection.
- Enter the number of the channel you wish to view using the number keys on the remote control.
- Select the channel in the Interactive Program Guide.

### Adjusting the Volume

Press volume + or – on the remote control to adjust the volume. When you adjust the volume, the volume scale is displayed on the screen. Press mute on the remote control to toggle the sound on and off.

For best audio quality when using the analog L/R (var.) volume controlled audio outputs, use the remote control to set the DCX set-top to approximately three quarters of the maximum volume level and then adjust the audio levels on external devices such as your TV or A/V receiver.

When using the analog L/R (fixed) audio outputs or any of the digital audio outputs (HDMI, IEEE-1394, optical digital audio) adjust the audio levels on your external device such as your TV or A/V receiver. You may also be able to program your remote to control the volume of your TV or A/V receiver directly (refer to the remote control instruction manual).

### Interactive Program Guide

The Interactive Program Guide displays information about TV programs and enables you to access features such as Parental Control or Pay-Per-View. Interactive program guides can vary with each cable service provider. Refer to the Interactive Program Guide's instruction manual for detailed instructions.

## Video Format Indicators (Front Panel Display)

The front panel display of the DCX3510-M set-top is equipped with indicators to the right hand side of the display that are used to indicate the currently-selected video output format on the component video (YPbPr) and HDMI outputs.

The DCX3510-M set-top is capable of providing the following video formats on the YPbPr and HDMI video outputs:

- High Definition 1080i (1920 x 1080 pixels)
- High Definition 720p (1280 x 720 pixels)
- Enhanced Definition 480p (720 x 480 pixels)
- Standard Definition 480i (720 x 480 pixels)

The DCX3510-M set-top is also capable of passing through High-Definition 1080p 24/30/60 (1920 x 1080 pixels) source content over the HDMI video output.

If you cannot get a video display when the DCX set-top is connected to your television via component video or standard HDMI cables, use the User Settings Menu to optimize the DCX3510-M set-top display settings for your television.

*Note: Availability of certain features is dependent upon application support.*

## M-Card™

The M-Card is required to view cable television programs, previously recorded programs on the DVR, or interactive on-demand programs. The M-Card should not be removed.

# 3

## Digital Video Recorder (DVR)

The DCX3510-M set-top is equipped with an internal hard drive for DVR (Digital Video Recorder) functionality, which provides the ability to record both Standard Definition TV (SDTV) and High Definition TV (HDTV) programs. Storage time varies based on the video format and specific channel.

The DCX3510-M set-top is also equipped with an eSATA interface on the rear panel. This interface allows the connection of an external hard disk drive to increase the DVR storage capacity of the DCX3510-M. *Note: your service provider must authorize your DCX3510-M for external DVR functionality.*

DVR offers the ability to control your viewing experience by pausing (time shifting) live TV and providing trick playback modes (pause, fast forward, slow forward, fast rewind, slow rewind). You may experience a slight delay when switching between time-shifted and live TV.

The DCX3510-M model also includes integrated MoCA™ networking which supports whole-home DVR capabilities. This feature extends the DVR experience to DCX3200-M or other compatible non-DVR set-tops with integrated MoCA, when enabled by application software. On your non-DVR set-top you can now view your DVR recordings, playback content, and set future recordings all from another room in your home.

With the DCX3510-M set-top, you can:

**Record Programming.** The total hours of recorded content will vary based on the storage capacity of your DVR, the storage capacity of your specific external drive (if authorized), and type of content (digital SD or HD and encoding method, MPEG-2 or MPEG-4) being recorded.

Drive Size	Estimated Recording Hours	
	Standard Definition	High-Definition
500GB	350 to 700 (MPEG-4)	100 to 160 (MPEG-4)
	175 to 350 (MPEG-2)	50 to 60 (MPEG-2)

**Maintain a Personal Program Library**—Accessed by using the Interactive Program Guide (IPG).

**Control Live TV**—Pause, rewind, and fast-forward live TV.

**Simultaneously Watch Two Programs**—Watch two programs and easily switch between them using the swap key on your remote control. (Dependent upon program guide support and provided remote control.)

**Simultaneous Watch and Record**—Record one program in the background while viewing another live broadcast at the same time.

**Simultaneously Record Two Shows**—Record two programs from two different channels at the same time.



**Simultaneously Record Two Shows and Watch a Recorded Program**—Watch a program recorded on your DVR while recording up to two other programs at the same time. You can also easily switch from viewing the pre-recorded program and either of the programs you're recording.

**Play Recorded Programming On Networked Set-tops In Your Home**—Using integrated MoCA networking, DCX3510-M recorded entertainment can be accessed by other compatible non-DVR set-tops with integrated MoCA, when enabled by application software.

## Using the External DVR Expansion Feature

To use the external DVR expansion feature of the DCX3510-M, first ensure that your service provider has authorized your DCX3510-M for external DVR functionality. If authorized, follow these steps to begin using the external DVR feature:

1. Power on your DCX3510-M and your television and ensure that you have a picture.
2. Connect a compatible eSATA hard disk drive to the DCX3510-M using the eSATA cable supplied with your external drive enclosure. The DCX3510-M will automatically detect that a hard disk drive has been connected to the eSATA interface.
3. The DCX3510-M will display an alert that an external hard disk drive has been connected and that it must be formatted. Use the remote control to confirm the format (formatting a drive will erase any and all content that on the drive).
4. The DCX3510-M displays a message when formatting is complete and if the operation succeeded or failed.

*During formatting of the external hard disk drive, the DCX3510-M will perform several tests to determine if the hard drive's performance is acceptable for DVR functionality. If the hard drive is unable to pass these performance tests, the DCX3510-M will alert you that the external drive is not compatible for DVR use.*

5. The DCX3510-M will confirm that an external drive is connected and available for use.

While using the external DVR expansion feature of your DCX3510-M:

- Recordings made on the external hard disk drive can only be played back on the same DCX3510-M used to record the programs. You cannot connect your external hard disk drive to another DCX3510-M (or another cable box with an eSATA interface) and watch programs that have been recorded on the hard drive.
- You can use multiple external hard disk drives with the same DCX3510-M, however; you can only watch the recordings that are available on the drive connected to the DCX3510-M at that time. To watch recordings that you made on another external drive, simply disconnect the external drive, follow the on-screen prompts, reconnect the other external drive, and again follow the on-screen prompts.
- Whenever the DCX3510-M reboots, a temporary loss of the program listings in the interactive program guide (IPG) is possible.

# 4

## Connecting Your DCX Set-top

Instructions and diagrams are included for the following connections:

- High-Definition Television (HDTV)
- A/V receiver — Audio
- Standard-Definition TV (SDTV)
- Standard-Definition TV (SDTV) and VCR/DVD Recorder
- A/V receiver, Standard-Definition TV (SDTV), and VCR/DVD Recorder

Before you move or change components on your entertainment system, review the following:

- For basic cable connections, use 75 ohm coaxial cables equipped with F type connectors.
- Disconnect power from your equipment before connecting or changing cable connections.

---

*Caution:* Do not place anything on top of your DCX set-top, especially other home entertainment components. Be sure to provide adequate ventilation to prevent overheating.

---

### Video Connection Options

The DCX set-top offers several different video connection options. Component video, HDMI, and IEEE-1394 allow you to view both High-Definition and Standard-Definition TV programming. Composite video connections allow you to view only Standard-Definition TV programming. HD programming will be down-converted to SD format for SD outputs.

To determine whether your TV features component video, HDMI, IEEE-1394, or composite video, check the manual supplied with your TV.

Use the guidelines below to determine the best video connection for your home entertainment system.

*Note:* Only (1) video connection to the TV is required. HD video can only be viewed with HDMI, IEEE-1394, or component video connections.

### HDMI or IEEE-1394 — HDTV and SDTV

HDMI and IEEE-1394 offer higher quality HD video than component video.

- If your TV has an HDMI input, this is for both audio and video. Connect a Standard HDMI cable to the TV and to the HDMI connector on your DCX set-top.
- HDMI and IEEE-1394 outputs provide video and audio, so no separate audio connections are required if you plan to use your TV's speakers as the primary audio source.
- On-screen graphics will not be displayed when you are using the IEEE-1394 connection on the rear panel of the DCX set-top. Refer to Section 6 for more information.

- If your TV has a DVI input, connect a HDMI-to-DVI adapter or cable to the HDMI out connector on the DCX set-top and the DVI HDTV connector on your TV.

*Note: DVI does not provide audio. A separate audio connection must be made.*

## **Component Video (YPbPr) — HDTV and SDTV**

The YPbPr connectors on your DCX set-top provide HDTV and SDTV component video.

*Note: Component video does not provide audio. A separate audio connection must be made.*

## **Composite Video — SDTV**

The Composite Video connector on your DCX set-top provides an SDTV Video connection.

*Note: Composite video does not provide audio. A separate audio connection must be made.*

## Connecting an HDTV — Single Connection for Video/Audio

### Cable In

Connect an RF coaxial cable to the cable wall outlet and the CABLE IN connector on the DCX set-top.

### HDMI

If your TV has an HDMI input, this is for both audio and video if you are using the TV speakers. Connect a Standard HDMI cable to the TV and to the HDMI connector on your DCX set-top.

### IEEE-1394

If your HDTV has an IEEE-1394 connector, you can use the IEEE-1394 for both your video and audio connection. Connect an IEEE-1394 cable to the IEEE-1394 connector on your HDTV and DCX set-top.

*Note: On-screen graphics will not be displayed when you are using the IEEE-1394 connection on the rear panel of the DCX set-top. Refer to [On-Screen Graphics](#) for more information.*

If you have an audio/video receiver and are not using your TV's speakers, go to [Connecting an A/V Receiver — Audio](#).

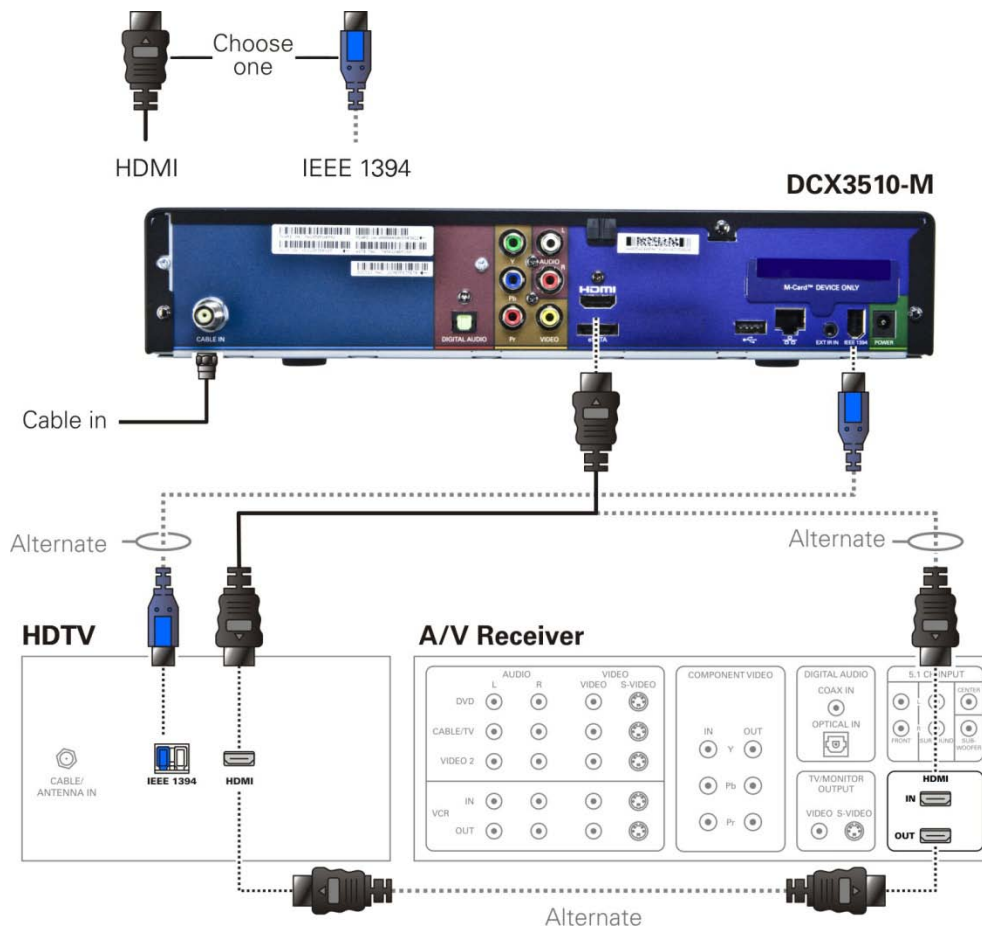

**Figure 3: Connecting an HDTV — Single Connection for Video/Audio**

*Note: Only one HDTV video connection needs to be made to an HDTV.*

*Note: On-screen graphics will not be displayed when using IEEE-1394 connection. Refer to [On-Screen Graphics](#) for more information.*

*Note: Solid lines indicate optimum connections.*

*Note: Optional HDMI connection to A/V Receiver shown but not required.*

## Connecting an HDTV — Separate Video/Audio Connections

### Cable In

Connect an RF coaxial cable to the cable wall outlet and the CABLE IN connector on the DCX set-top.

### DVI

If your TV has a DVI input, use the DVI connection for your video, connect a HDMI-to-DVI adapter or cable to the HDMI out connector on the DCX set-top and the DVI-HDTV connector on your TV.

*Note: A DVI connection supports only the video connection between the DCX set-top and the HDTV.*

*To connect your audio connections with your TV speakers, go to the [Audio](#) section below.*

*To connect your audio connections for an A/V receiver, go to [Connecting an A/V Receiver — Audio](#).*

### Component Video (YPbPr)

Connect the component video cables to the **Y**, **Pb**, and **Pr** connectors on your HDTV and DCX set-top.

*Note: This connection supports only the high definition video connection between the DCX set-top and the HDTV.*

*Note: Be sure to match up each signal to the same connection on the TV, otherwise the colors will not appear correctly on your TV.*

*To connect your audio connections with your TV speakers, go to the [Audio](#) section.*

*To connect your audio connections for an A/V receiver, go to [Connecting an A/V Receiver — Audio](#).*

### Audio

If your TV does not have digital audio inputs, connect the stereo audio cable to the audio L/R connectors on the DCX3510-M set-top and the Audio L/R connectors on the HDTV.

If your TV supports digital audio inputs, use the digital audio optical S/PDIF outputs instead of the audio L/R outputs. S/PDIF offers better audio quality, including support for Dolby® Digital audio.

*For information on configuring your DCX set-top settings, go to [Configuring the User Settings](#).*

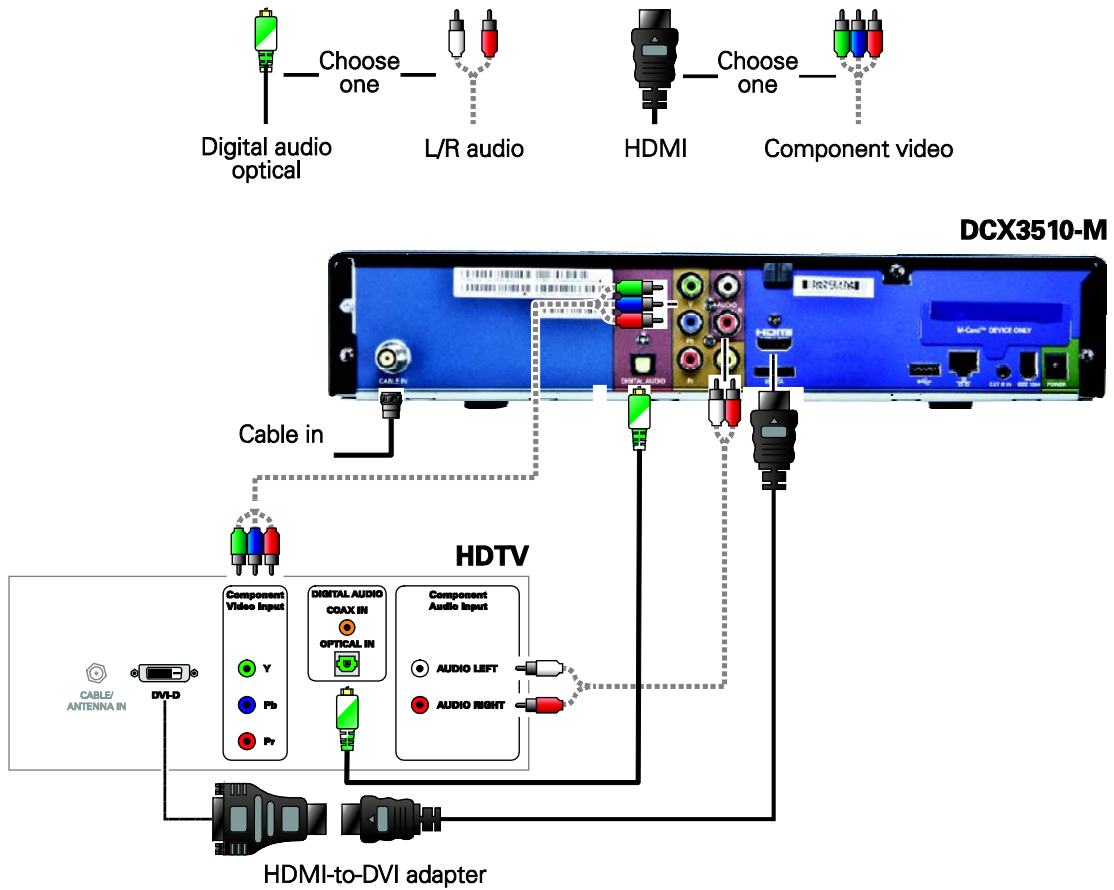

**Figure 4: Connecting an HDTV — Separate Video/Audio Connections**

*Note: Only one video connection and one audio connection need to be made to an HDTV.*

*Note: HDMI-to-DVI adapter is not included with the set-top.*

*Note: Solid lines indicate optimum connections.*

## Connecting an A/V Receiver — Audio

There are several options available for audio connections to your A/V receiver:

- Digital audio (OPTICAL S/PDIF)
- Stereo audio (AUDIO L/R)

If your A/V receiver supports it, the optical (S/PDIF) digital audio outputs may be used in place of the stereo audio outputs (audio L/R). These outputs offer a higher level of audio quality, including support for Dolby Digital audio.

- **Digital audio optical (S/PDIF)**—Connect the optical cable to the digital audio OPTICAL connector on the DCX set-top and the optical connector on the A/V receiver.
- **Stereo audio**—Connect the stereo audio cable to the audio L/R connectors on the DCX set-top and the audio L/R connectors on the A/V receiver.

For information on configuring your DCX set-top settings, see [Configuring the User Settings](#).



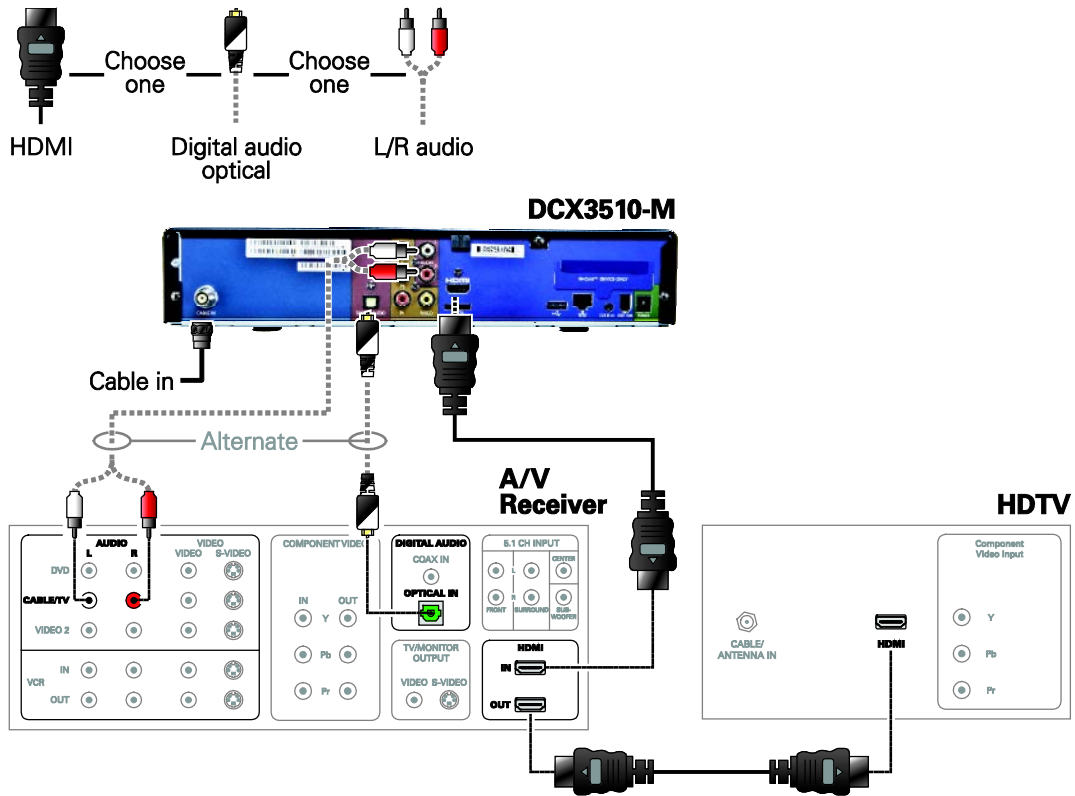

**Figure 5: Connecting an A/V Receiver — Audio**

*Note: Only one audio connection needs to be made to an HDTV.*

*Note: Solid lines indicate optimum connections.*

## Connecting an SDTV

1. Connect the stereo audio cable to the AUDIO OUT L/R connectors on the DCX set-top and the audio L/R connectors on the Standard-Definition TV (SDTV).
2. Connect a Video Composite cable to the Video Composite connector on the DCX set-top and the input Video Composite on the TV.

*These video connection methods do not support HD video. If you have an HDTV, see [Connecting an HDTV — Single Connection for Video/Audio](#).*

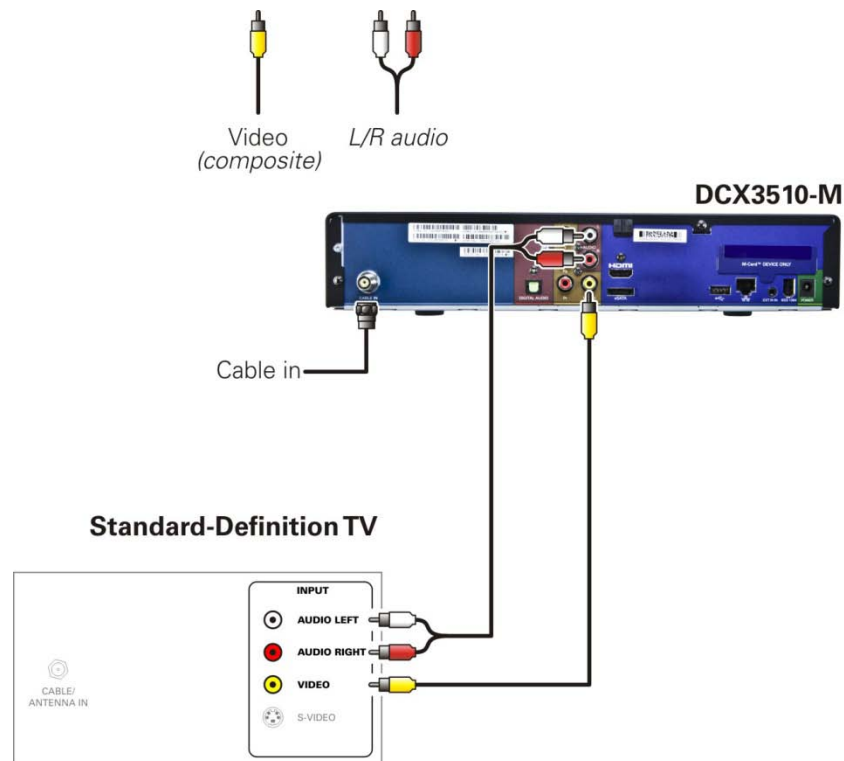

**Figure 6: Connecting an SDTV**

*Note: Composite video requires separate audio connections.*

*Note: Only one video connection and one audio connection is required.*

*Note: Solid lines indicate optimum connections.*

## Connecting a Standard-Definition TV (SDTV) and VCR/DVD Recorder

1. Connect a stereo audio cable to the AUDIO OUT L and R connectors on the DCX3510-M Series set-top and the INPUT AUDIO L and R connectors on the VCR/DVD Recorder.
2. Connect a video cable to the VIDEO OUT connector on the DCX3510-M Series set-top and the INPUT VIDEO connector on the VCR/DVD Recorder.
3. Connect a stereo audio cable to the OUTPUT AUDIO L and R connectors on the VCR/DVD Recorder and the INPUT AUDIO L and R connectors on the SDTV.
4. Connect a video cable to the OUTPUT VIDEO connector on the VCR/DVD Recorder and the INPUT VIDEO connector on the SDTV.

*Note: These video connection methods do not support HD video. If there is an HDTV, see [Connecting HDTV — Separate Video/Audio Connections](#).*

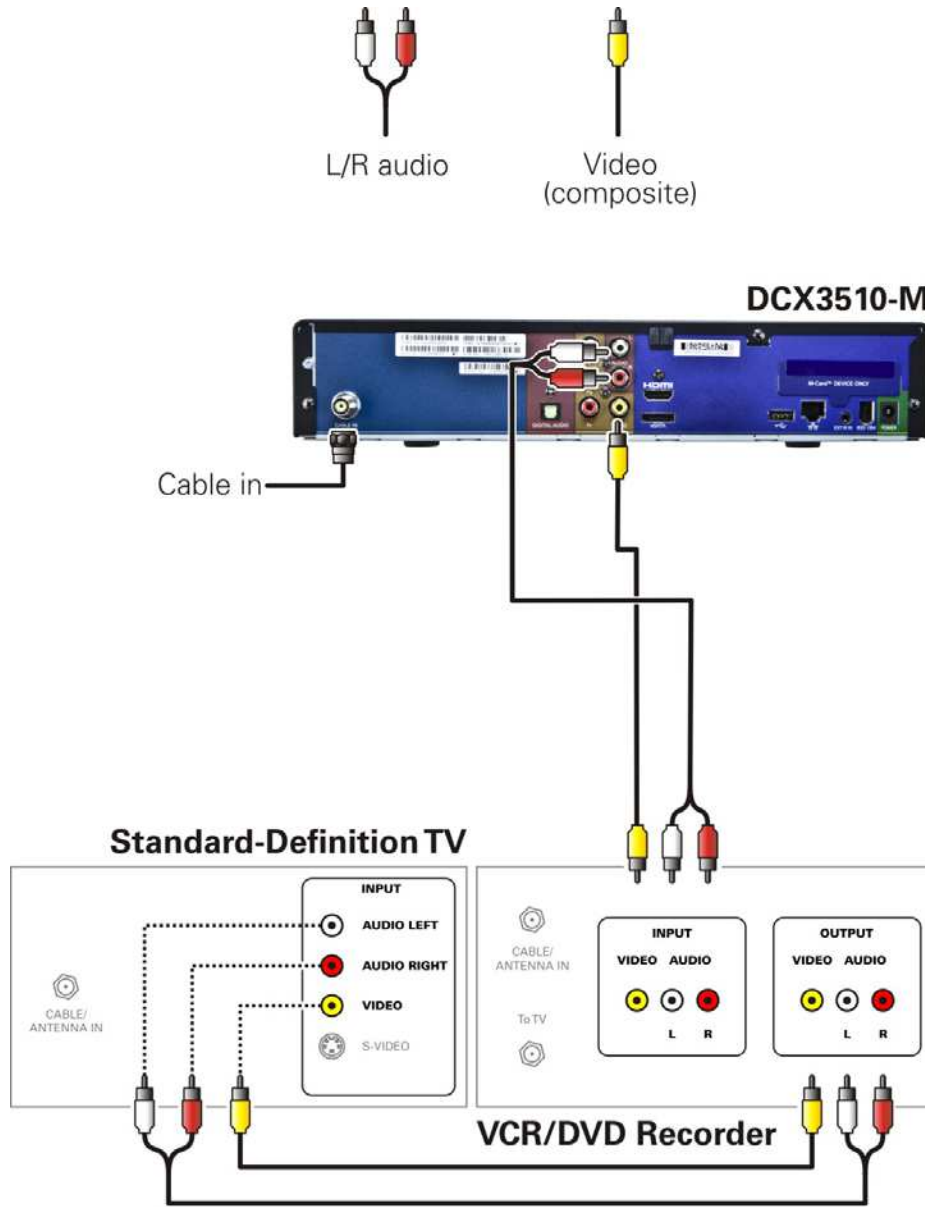

Figure 7: Connecting a Standard-Definition TV (SDTV) and VCR/DVD Recorder

## Connecting an A/V Receiver, SDTV, and VCR/DVD Recorder

1. Connect a stereo audio cable to the AUDIO OUT L/R connectors on the DCX set-top and the input L/R connectors on the A/V receiver.
2. Connect a Video Composite cable to the Video Composite connector on the DCX set-top and the Video Composite connector on the A/V receiver.
3. Connect a stereo audio cable to the VCR AUDIO OUT L/R connectors on the A/V receiver and the INPUT AUDIO L/R connectors on the stereo VCR.
4. Connect a stereo audio cable to the output AUDIO OUT L/R connectors on the stereo VCR and the VCR audio in L/R connectors on the A/V receiver.
5. Connect a composite video cable to the input video connector on the stereo VCR and the video VCR OUT connector on the A/V receiver.
6. Connect a composite video cable to the output video connector on the stereo VCR and the video VCR IN connector on the A/V receiver.
7. Connect a Composite Video cable to the input Composite Video connector on the Standard-Definition TV (SDTV) and the TV/monitor output Composite Video connector on the A/V receiver.

*Note: The digital audio optical (optical S/PDIF) audio outputs may be used in place of the stereo audio outputs (audio L/R). Optical S/PDIF offers a higher level of audio quality, including support for Dolby Digital audio.*

*These video connection methods do not support HD video. If you have an HDTV, see [Connecting an HDTV — Single Connection for Video/Audio](#).*

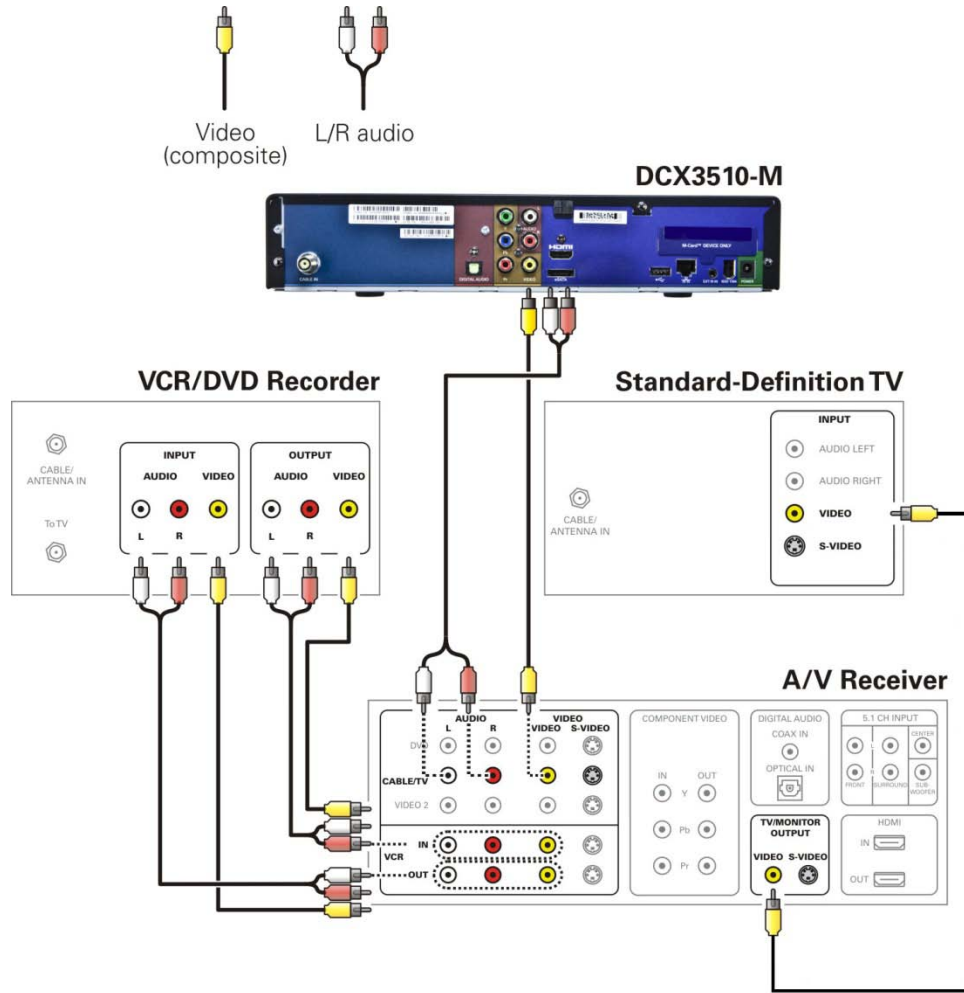

**Figure 8: Connecting an A/V Receiver, SDTV, and VCR/DVD Recorder**

*Note: Solid lines indicate optimum connections.*

*Note: Consult your A/V receiver manual for additional wiring options or constraints when including a VCR/DVD Recorder in your configuration.*

## Connecting Your Set-top to an External eSATA DVR

1. Contact your cable service provider to verify the set-top software necessary to support External DVR Storage is available in your area.
2. Connect the AC power cord to the external drive and plug the external drive's AC power adapter into an electrical outlet.
3. Allow approximately 15 to 30 seconds for the external drive to reach operating speed.
4. Connect one end of the eSATA cable to the set-top.
5. Connect the other end of the eSATA cable to the external drive.
6. Follow the on-screen instructions.

*Note: Only connect external hard drives that have been approved by ARRIS for external DVR service. Connecting an external drive that has not been approved could result in poor DVR performance.*

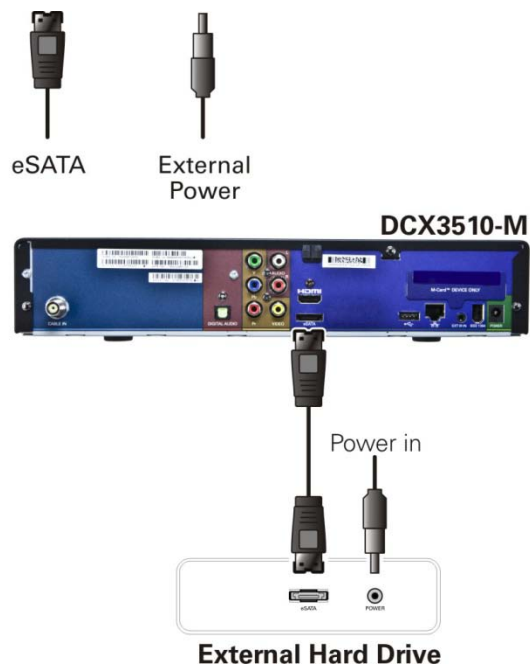

**Figure 9: Connecting Your Set-top to an External eSATA DVR**

## Data Devices

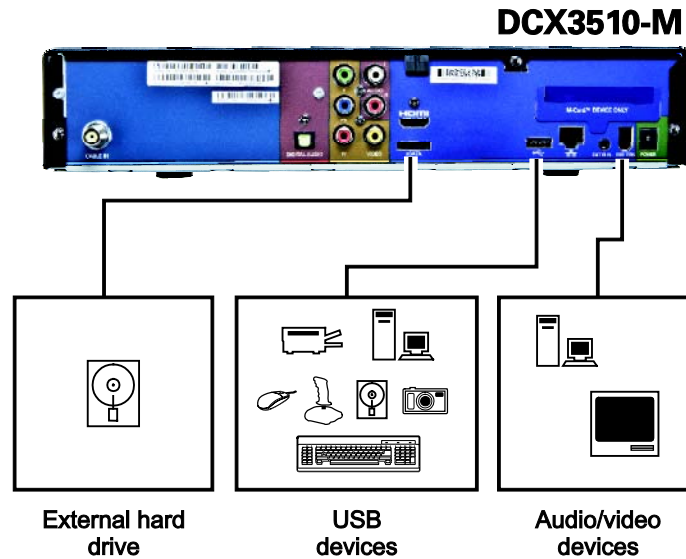

**Figure 10: Data Device Connections**

Do not attempt to connect data devices without contacting your service provider. Advanced data features require the proper application and network infrastructure to operate.

## Data Features

In addition to high-quality audio and video, the DCX set-top has the capability to deliver high-speed data services such as Internet access, e-mail, IP telephony, e-commerce, and home banking.

*Note: Your DCX set-top may be equipped with the interface connections illustrated, but their functionality depends on the services offered by your service provider.*



## On-Screen Graphics

Your DCX set-top can generate graphics that overlay the video programming or fill the entire television screen. Common examples include on-screen menus (such as the User Setting menu), closed captions, and interactive program guides. The DCX set-top overlays these graphics whenever you open a menu, enable closed captions, or scroll through a program grid.

- On-screen graphics are not available on all video output combinations.
- On-screen graphics will not be displayed when you are using the IEEE-1394 connection on the rear panel of the DCX set-top.

# 5

## Recording Your Connections

Use this diagram to record connections between your home entertainment components. You can use this diagram to reconnect your system if you move the equipment or add new equipment.

Disconnect the power from the DCX set-top before connecting or changing cable connections. Do not place another component or object on top of the DCX set-top.

### DCX3510-M



#### VCR / DVD Recorder

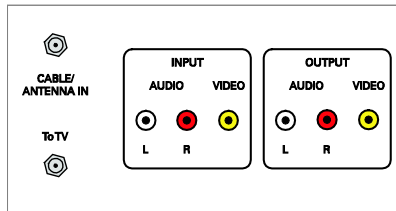

#### HDTV / Standard-Definition TV

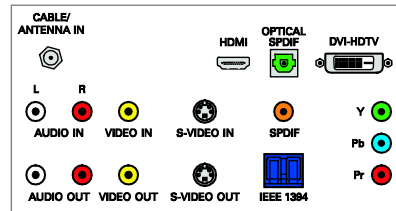

#### Audio receiver

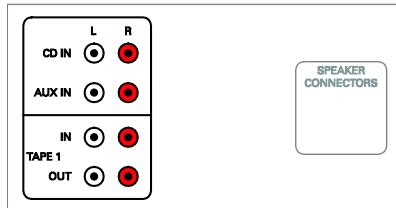

#### DVD player

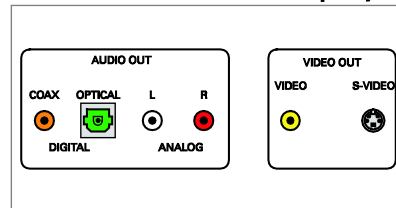

#### AV receiver

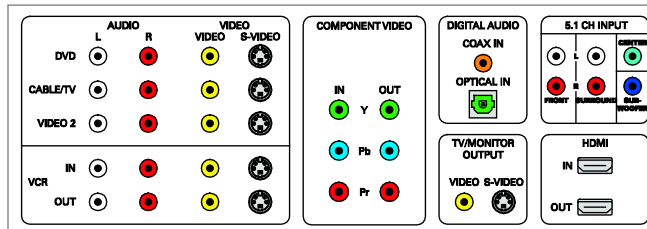

# 6

## Configuring the User Settings

The following describes how to configure the audio (for HDMI connections), SD and HD video, closed caption, subtitle, and power settings for the DCX3510-M.

Before you adjust the output settings:

1. Connect the DCX3510-M to the TV and other home entertainment devices.
2. Connect the provided power supply to the DCX3510-M and an AC power outlet.
3. Initialize the DCX3510-M and authorize it for services.
4. Turn the TV on.

*Note: When using an HDMI connection between the DCX3510-M and the television, be sure to have the cable connected and the TV powered on before adjusting the video settings.*

## User Settings Menu Main Screen

To configure the DCX3510-M settings on the main User Settings menu screen, first power off the DCX3510-M using either the remote control or the Power button and then press the MENU key on the remote control. If the TV is on, the on-screen User Settings menu lists the DCX3510-M settings that can be adjusted.

If no HDMI device is connected to the DCX3510-M, the default User Settings menu appears as follows:

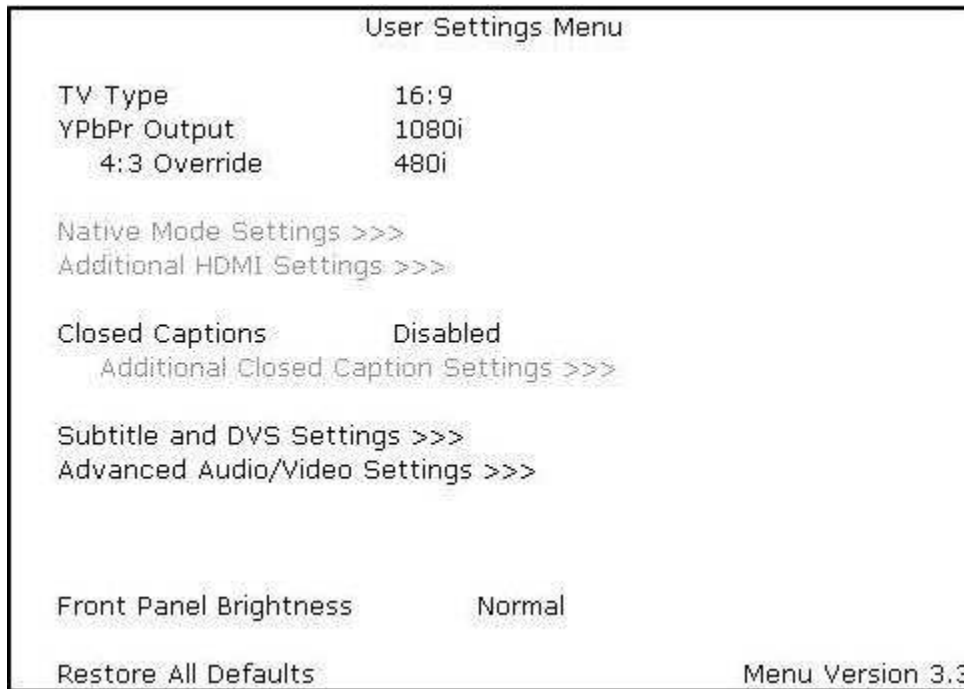

**Figure 11: Default User Settings Menu when no HDMI connection is in place**

If the DCX3510-M is connected via HDMI to a display device such as a television, the default User Settings menu is updated to reflect this information. The YPbPr Output menu option is replaced with the HDMI/YPbPr Output menu option as shown in the following example.

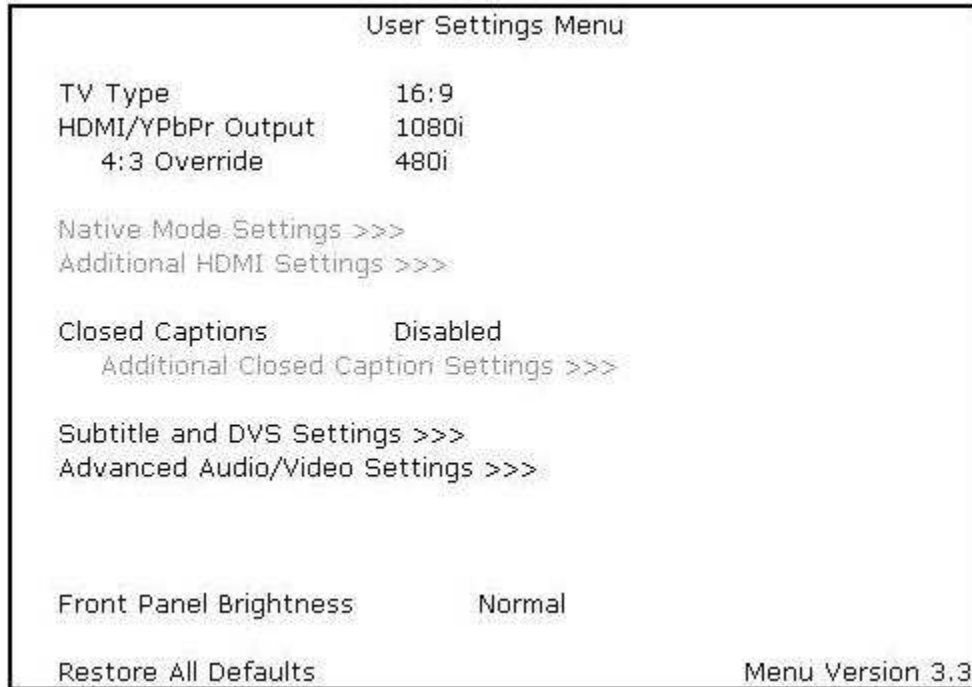

**Figure 12: Default User Settings Menu when an HDMI connection is in place**

Use the remote control cursor keys to navigate the on-screen menus as follows:

- Press the ▲ and ▼ keys to highlight the setting you wish to change.
- Press the ► key to select an option.
- To exit the setting and move to another setting, press the ▲ or ▼ key.

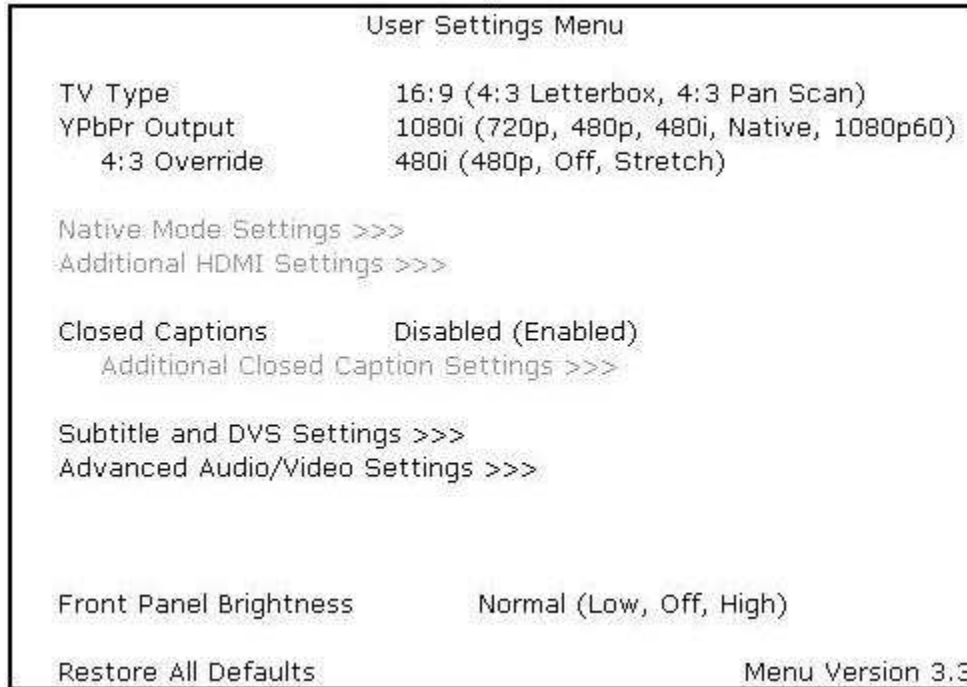

**Figure 13: User Settings Menu—Main Menu Screen**

**Table 1: User Settings Main Menu Field Descriptions**

Setting	Description
<b>TV Type</b>	<p>Allows you to specify the style of television connected to the DCX3510-M. The 16:9 option is the default.</p> <ul style="list-style-type: none"> <li>• <b>16:9</b>— A widescreen television is connected to the DCX3510-M.</li> <li>• <b>4:3 Letterbox</b> — A standard-screen television is connected to the DCX3510-M and widescreen programs should be scaled to fit the screen with black bars above and below the picture.</li> <li>• <b>4:3 Pan Scan</b>—A standard-screen television is connected to the DCX3510-M and widescreen programs should be cropped so the picture fills the entire screen.</li> </ul>

Setting	Description
<b>HDMI/YPbPr Output</b>	<p>Allows you to select the video format of the HDMI and/or Component Video (YPbPr) outputs:</p> <ul style="list-style-type: none"> <li>• For ALL programs when the 4:3 Override setting is set to either Off or Stretch.</li> <li>• For ONLY widescreen programs when the 4:3 Override is set to either 480i or 480p.</li> </ul> <p>The 1080i option is the default.</p> <ul style="list-style-type: none"> <li>• <b>1080p60</b>—High-Definition 1080p60 format (1920 x 1080 pixels with progressive scanning at 60 frames per second).</li> <li>• <b>1080i</b>—High-Definition 1080i format (1920 x 1080 pixels with interlaced scanning at 30 frames per second).</li> <li>• <b>720p</b>—High-Definition 720p format (1280 x 720 pixels with progressive scanning at 60 frames per second).</li> <li>• <b>480p</b>—Enhanced-Definition 480p format (720 x 480 pixels with progressive scanning at 60 frames per second).</li> <li>• <b>480i</b>—Standard-Definition 480i format (720 x 480 pixels with interlaced scanning at 30 frames per second).</li> <li>• <b>Native</b>—Format that most closely matches the program’s native format according to the list of compatible formats selected from the Native Mode Settings menu screen.</li> </ul> <p><i>Note : Not all televisions will support all available video formats. Consult the television’s user manual for more information on video format compatibility.</i></p> <p><i>The DCX3510-M can detect when the HDMI connection is in use. If you are not using the HDMI connection on the DCX3510-M, the HDMI/YPbPr Output setting will display as YPbPr Output in the User Settings Menu.</i></p> <p><i>Most new HDTVs are equipped with at least one HDMI input and can support the 1080p60 format. The DCX3510-M is designed to provide excellent video quality when converting any program to the 1080p60 video format. If your television supports 1080p60 video input, it is highly recommended to adjust the HDMI/YPbPr Output setting to the 1080p60 setting.</i></p>

Setting	Description
<b>4:3 Override</b>	<p>Allows you to select the video output format of the DCX3510-M when it is tuned to a Standard-Definition program or playing back a Standard- Definition program from the DVR. The 480i option is the default.</p> <ul style="list-style-type: none"> <li>• <b>480i</b>—Standard-Definition 480i format (720 x 480 pixels).</li> <li>• <b>480p</b>—Enhanced-Definition 480p format (720 x 480 pixels).</li> <li>• <b>Stretch</b>—Automatically stretch all Standard-Definition programs to a widescreen (16:9) aspect ratio and present the video in the format designated by the HDMI/YPbPr Output setting. Note that the Stretch option is only available when the TV Type setting is 16:9.</li> <li>• <b>Off</b>—Widescreen version of a Standard-Definition program with black bars to the left and the right of the picture (pillarbox) and the video presented in the format designated by the HDMI/YPbPr Output setting.</li> </ul> <p><i>Note: Not all televisions support all available video formats. Consult your television's user manual for more information on format compatibility.</i></p> <p><i>If the HDMI/YPbPr Output setting is set to either 480i or Native, the 4:3 Override feature is disabled and can't be selected in the menu. The 4:3 Override feature is available when the HDMI/YPbPr Output setting is 1080i, 720p, or 480p.</i></p>
<b>Native Mode Settings</b>	<p>Allows you to customize the Native Mode feature of the DCX3510-M by selecting the video formats supported by your television.</p> <p>Selecting the Native Mode Settings option presents a new menu screen with settings specific to Native Mode operation. These settings are discussed in more detail below.</p> <p>The Native Mode Settings option is only available when the HDMI/YPbPr Output setting is set to Native. Otherwise, the Native Mode Settings option is disabled and can't be selected in the menu.</p>
<b>Additional HDMI Settings</b>	<p>Available whenever an HDMI device is connected to the DCX3510-M. Selecting this option presents a new menu screen with settings specific to the HDMI connection. These settings are discussed in more detail below.</p> <p>If no HDMI device is connected to the DCX3510-M, this option is disabled and can't be selected in the menu.</p>
<b>Closed Captions</b>	<p>Turns closed captions off or on.</p> <p>When this option is set to Disabled, the DCX3510-M does not render (draw) closed captions on any video output.</p> <p>When this option is set to Enabled, the DCX3510-M renders (draws) closed captions on all video outputs if closed captions are included in the program.</p> <p>Disabled is the default setting.</p>
<b>Additional Closed Caption Settings</b>	<p>Allows you to customize the style and appearance of closed captions.</p> <p>Selecting this presents a new menu screen with settings specific to closed captions, including font style, color, and size. These settings are discussed in more detail below.</p> <p>The Additional Closed Caption Settings option is only available when the Closed Captions setting is set to Enabled. Otherwise, the Additional Closed Caption Settings option is disabled and can't be selected in the menu.</p>



Setting	Description
<b>Subtitle and DVS Settings</b>	<p>Allows you to customize the operation of the subtitle and descriptive video service features.</p> <p>Selecting the Subtitle and DVS Settings option presents a new menu screen with settings specific to subtitle and descriptive video service operation. These settings are discussed in more detail below.</p>
<b>Advanced Audio/Video Settings</b>	<p>Allows you to customize several advanced audio and video features of the DCX3510-M.</p> <p>Selecting this option presents a new menu screen with settings specific to closed captions, including font style, color, and size. These settings are discussed in more detail below.</p>
<b>Front Panel Brightness</b>	<p>Allows you to adjust the brightness level of the front panel display (clock/channel number and indicator icons) of the DCX3510-M.</p> <ul style="list-style-type: none"> <li>• <b>High</b>—The brightest level. This setting is most useful when using the DCX3510-M in very brightly lit rooms.</li> <li>• <b>Normal</b>—The default brightness level.</li> <li>• <b>Low</b>—The lowest (visible) brightness level. This setting is most useful when using the DCX3510-M in dim or dark rooms.</li> <li>• <b>Off</b>—The front panel display will be turned off completely, including the clock/channel number and all indicator icons. The blue backlighting of the front panel Power button remains illuminated.</li> </ul>
<b>Restore All Defaults</b>	<p>To reset ALL of the DCX3510-M User Settings to their default values, including options stored on other menu screens, move the cursor to this option and press the ► key.</p>

## Native Mode Settings Screen

The Native Mode Settings menu is used to configure the operation of the native mode feature on the DCX3510-M. The DCX3510-M is capable of receiving and decoding a number of different digital video formats. When operating in native mode, the DCX3510-M generates the video output format that most closely matches the broadcast video format.

For example, if the DCX3510-M is configured to operate in native mode, a channel broadcast in the 720p format is output to the television in the 720p format, while a channel broadcast in the 1080i format is output to the television in the 1080i format.

When using the native mode feature of the DCX3510-M, please exercise caution when selecting the formats from the checklist. If a format is selected that is not compatible with the television, there may be a loss of video whenever the DCX3510-M is tuned to a channel that is broadcast in that format.

If the television is connected to the DCX3510-M using an HDMI cable, the DCX3510-M automatically customizes the checklist of supported formats reported to it by the television. If the television is connected to the DCX3510-M using Component Video (YPbPr) cables, the checklist needs to be customized manually.

*Note: At least one of the [1080p - 1080i - 720p - 480p - 480i] formats must be selected from the checklist for the DCX3510-M to operate properly in native mode.*

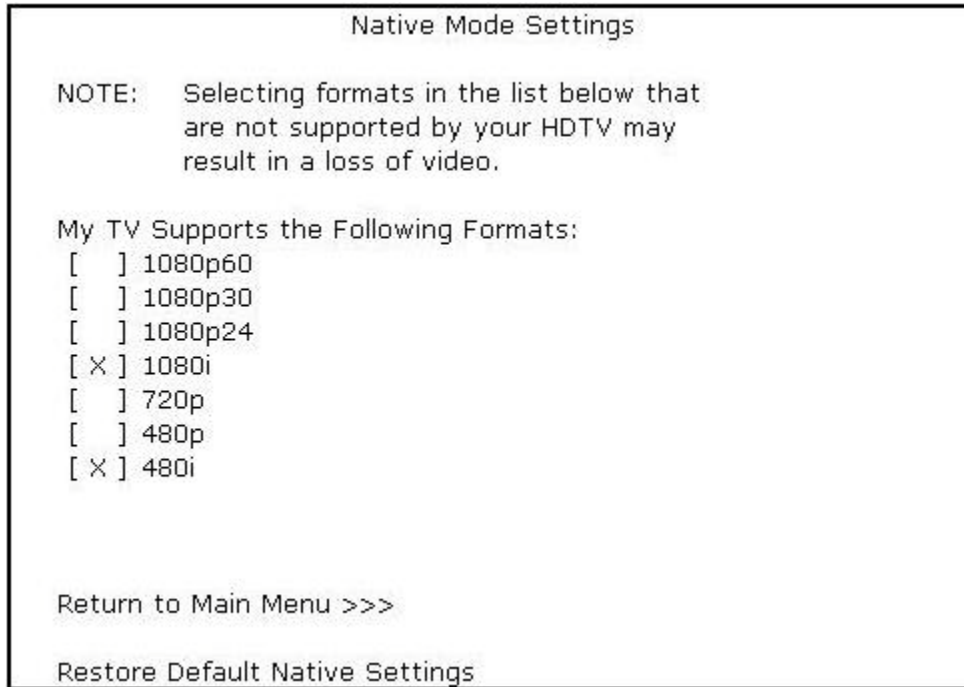

**Figure 14: Native Mode Settings menu screen**

**Table 2: Native Mode Settings Field Definitions**

Setting	Description
<b>1080p60 (High Definition)</b>	<p>Generates 1080p60 video on the HDMI output if the program is broadcast in 1080p60 format. The DCX3510-M can also convert any other broadcast format to the 1080p60 video format.</p> <p>1080p60 is a high-definition video image with 1920 x 1080 pixels, progressive scanning, and a frame rate of 60 frames per second.</p> <p>This option is only available if the DCX3510-M is connected to an HDMI display device. If no HDMI connection is detected, this option is disabled and can't be selected in the menu.</p> <p><i>Note: The Component Video (YPbPr) output delivers 480i video whenever the HDMI output is delivering 1080p60 video.</i></p>
<b>1080p30 (High Definition)</b>	<p>Generates 1080p30 video on the HDMI output if the program is broadcast in 1080p30 format. The DCX3510-M cannot convert any other broadcast format to the 1080p30 video format.</p> <p>1080p30 is a high-definition video image with 1920 x 1080 pixels, progressive scanning, and a frame rate of 30 frames per second.</p> <p>This option is only available if the DCX3510-M is connected to an HDMI display device. If no HDMI connection is detected, this option is disabled and can't be selected in the menu.</p> <p><i>Note: The Component Video (YPbPr) output delivers 480i video whenever the HDMI output is delivering 1080p30 video.</i></p>

Setting	Description
<b>1080p24 (High Definition)</b>	<p>Generates 1080p24 video on the HDMI output if the program is broadcast in 1080p24 format. The DCX3510-M cannot convert any other broadcast format to the 1080p24 video format.</p> <p>1080p24 is a high-definition video image with 1920 x 1080 pixels, progressive scanning, and a frame rate of 24 frames per second.</p> <p>This option is only available if the DCX3510-M is connected to an HDMI display device. If no HDMI connection is detected, this option is disabled and can't be selected in the menu.</p> <p><i>Note: The Component Video (YPbPr) output delivers 480i video whenever the HDMI output is delivering 1080p24 video.</i></p>
<b>1080i (High Definition)</b>	<p>Generates 1080i video on both the HDMI and Component Video (YPbPr) outputs if the program is broadcast in 1080i format. The DCX3510-M can also convert any other broadcast format to the 1080i video format.</p> <p>1080i is a high-definition video image with 1920 x 1080 pixels, interlaced scanning, and a frame rate of 30 frames per second.</p>
<b>720p (High Definition)</b>	<p>Generates 720p video on both the HDMI and Component Video (YPbPr) outputs if the program is broadcast in 720p format. The DCX3510-M can also convert any other broadcast format to the 720p video format.</p> <p>720p is a high-definition video image with 1280 x 720 pixels, progressive scanning, and a frame rate of 60 frames per second.</p>
<b>480p (Enhanced Definition)</b>	<p>Generates 480p video on both the HDMI and Component Video (YPbPr) outputs if the program is broadcast in 480p format. The DCX3510-M can also convert any other broadcast format to the 480p video format.</p> <p>480p is an enhanced-definition video image with 720 x 480 pixels, progressive scanning, and a frame rate of 60 frames per second.</p>
<b>480i (Standard Definition)</b>	<p>If this option is selected, the DCX3510-M generates 480i video on both the HDMI and Component Video (YPbPr) outputs if the program is broadcast in 480i format. The DCX3510-M can also convert any other broadcast format to the 480i video format.</p> <p>480i is a standard-definition video image with 720 x 480 pixels, interlaced scanning, and a frame rate of 30 frames per second.</p>
<b>Restore Default Native Settings</b>	<p>Selecting this option will restore the checklist of video formats to its default configuration. Use this option if audio and/or video has been lost after adjusting these settings from their default values.</p> <p>If you are the HDMI connection to your television, the checklist will be automatically customized according to the supported formats reported by the television.</p> <p>If you are using the Component Video (YPbPr) connection to your television, the checklist will have only the 1080i and 480i formats selected.</p>
<b>Return to Main Menu</b>	<p>Selecting this option will return you to the User Settings Menu main screen.</p>

## Additional HDMI Settings Screen

The Additional HDMI Settings menu configures advanced options that affect the operation of the DCX3510-M with other HDMI and DVI display devices. Adjustable options include display mode, color space, audio output mode, and audio lip sync delay.

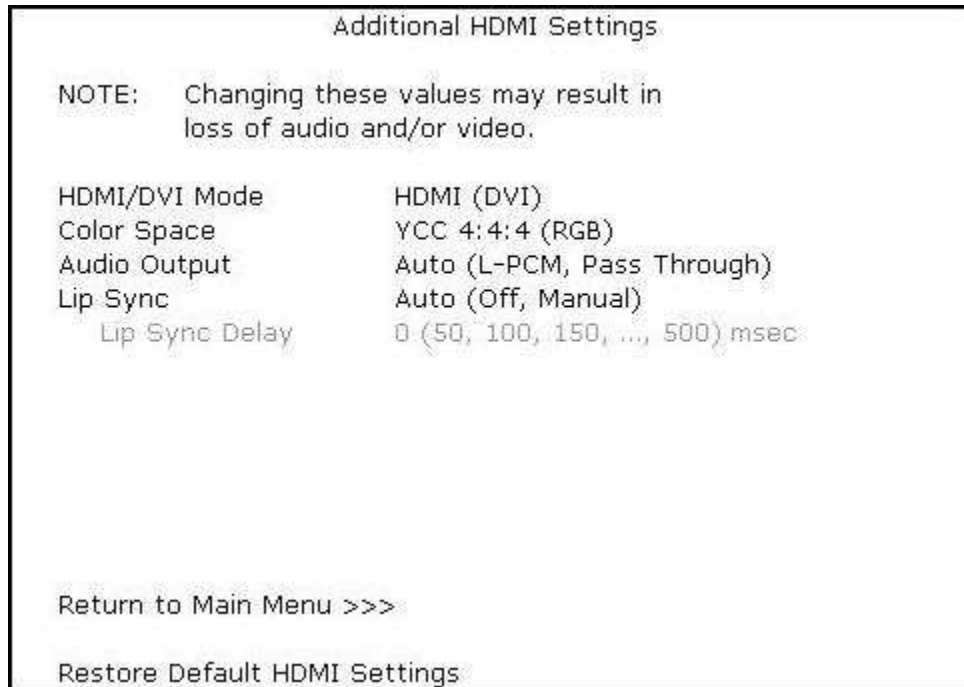

**Figure 15: Additional HDMI Settings screen**

**Table 3: Additional HDMI Settings Field Definitions**

Setting	Description
<b>HDMI/DVI Mode</b>	<p>Allows you to optimize the HDMI output to work with both DVI-equipped televisions and HDMI-equipped televisions. HDMI is the default setting.</p> <ul style="list-style-type: none"> <li>• <b>HDMI</b>—Optimized to work with an HDMI television or home theater receiver.</li> <li>• <b>DVI</b>—Optimized to work with a DVI television or display device (connected via an HDMI-to-DVI adapter).</li> </ul>
<b>Color Space</b>	<p>Allows you to adjust the color space used by the DCX3510-M to generate the video signals on the HDMI output. YCC 4:4:4 is the default setting.</p> <ul style="list-style-type: none"> <li>• <b>YCC 4:4:4</b>—Generates video signals within the YCC color space.</li> <li>• <b>RGB</b>—Generates video signals within the RGB color space.</li> </ul> <p><i>Note: Adjusting these settings could result in a loss of video. Only a professional installer or someone with a good working knowledge of the color spaces supported by the TV should change this setting.</i></p>
<b>Audio Output</b>	<p>Allows you to specify the digital audio format delivered over the HDMI output by the DCX3510-M. Options include Auto, L-PCM, and Pass Through. Auto option is the default setting.</p> <ul style="list-style-type: none"> <li>• <b>Auto</b>—Provides the digital audio format specified by the connected device (TV or home theater receiver) when that device was first connected to the DCX3510-M.</li> <li>• <b>L-PCM</b>—Provides all audio in the Linear Pulse Code Modulation digital audio format. The L-PCM format is widely supported by most HDMI televisions and home theater receivers.</li> <li>• <b>Pass Through</b>—Provides the same digital audio format on the HDMI output as is provided with the program being viewed at that time. For example, if the program has a Dolby Digital soundtrack, the DCX3510-M passes the Dolby Digital audio to the HDMI output. This option is most useful when connecting the DCX3510-M to a home theater receiver that has HDMI switching capability.</li> </ul> <p><i>Note: Adjusting these settings could result in a loss of audio. Only a professional installer or someone with a good working knowledge of the digital audio formats supported by the TV and/or home theater receiver should change this setting</i></p>
<b>Lip Sync</b>	<p>Allows you to adjust the amount of time the audio signal is delayed with respect to the video signal on the HDMI output. Some HDMI televisions and home theater receivers add an extra delay to the video signal during processing which can produce an effect where the audio noticeably “leads” the video.</p> <p>By default, this option is set to Auto. The options are used as follows:</p> <ul style="list-style-type: none"> <li>• <b>Auto</b>—The DCX3510-M automatically delays the audio signal on the HDMI output by the amount of time requested by the connected HDMI device.</li> <li>• <b>Manual</b>—The DCX3510-M delays the audio signal on the HDMI output by the amount of time selected for the <b>Lip Sync Delay</b> setting.</li> <li>• <b>Off</b>—The DCX3510-M will not delay the audio signal on the HDMI output.</li> </ul>

<b>Lip Sync Delay</b>	<p>Available when the Lip Sync option has been set to Manual.</p> <p>The Lip Sync Delay setting can be adjusted between 0 milliseconds and 500 milliseconds in 50 millisecond increments.</p> <p>If the Lip Sync option has been set to either Auto or Off, this option is disabled and can't be selected in the menu.</p> <p>Use this option to adjust the HDMI audio delay if you notice that the video image routinely seems to be "behind" the audio soundtrack when using your HDMI device.</p>
<b>Return To Main Menu</b>	<p>Returns you to the User Settings Menu main screen.</p>
<b>Restore Default HDMI Settings</b>	<p>Restores all of the settings on this screen (HDMI/DVI Mode, Color Space, Audio Output, and Lip Sync) to their default values.</p> <p>Use this option if you lose audio and/or video after changing these settings from their default values.</p>

## Additional Closed Caption Settings Screen

The Additional Closed Caption Settings adjusts the various display options for closed caption legibility. Customizable options include font size, font style, font color, and font opacity. You may also select to view different closed caption services if these are included within the broadcast program.

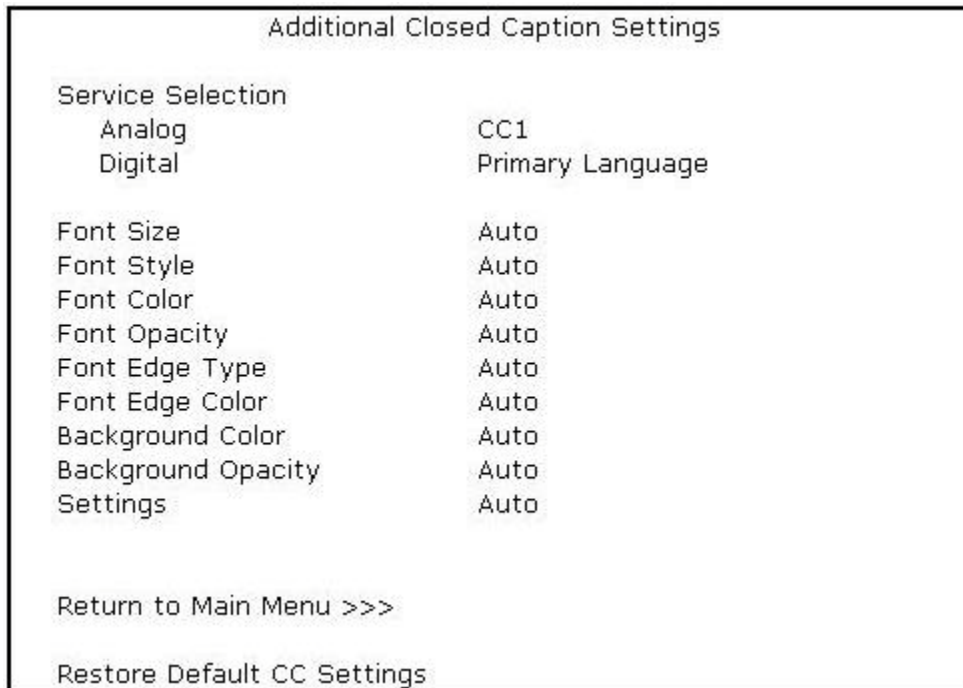

**Figure 16: Additional Closed Caption Settings menu screen**

**Table 4: Additional Closed Caption Settings Field Definitions**

Setting	Description
<b>Service Selection</b>	<p>Sets the service used by the DCX3510-M to render (draw) the closed captions:</p> <ul style="list-style-type: none"> <li>• <b>Analog</b>—Affects closed captions for analog and digital standard definition services. Available options are: CC1, CC2, CC3, CC4, T1, T2, T3, or T4. The default setting is CC1.</li> <li>• <b>Digital</b>—Affects closed captions for digital enhanced definition and high definition services. Available options are: Primary Language, Secondary Language, 3, 4, 5, or 6. The default setting is Primary Language.</li> </ul>
<b>Font Size</b>	Sets the font size used for rendering (drawing) closed captions. The default setting is Auto. Available options include: Auto, Standard, Large, or Small.
<b>Font Style</b>	Sets the font style used for rendering (drawing) closed captions. The default setting is Auto. Available options include: Auto, Mono Serif, Proportion Serif, Mono No Serif, Proportion No Serif, Casual, Cursive, or Small Capitals.
<b>Font Color</b>	Sets the font color used for rendering (drawing) closed captions. The default setting is Auto. Available options include: Auto, White, Black, Red, Green, Blue, Yellow, Magenta, or Cyan.
<b>Font Opacity</b>	Sets the opacity used for rendering (drawing) closed captions. The default setting is Auto. Available options include: Auto, Transparent, Translucent, Solid, or Flashing.
<b>Font Edge Type</b>	Sets the edge appearance used for rendering (drawing) closed captions. Available options include: Auto, None, Raised, Depressed, Uniform, Left Shadowed, or Right Shadowed. The default setting is Auto.
<b>Font Edge Color</b>	Sets the edge color used for rendering (drawing) closed captions. Available options include: Auto, White, Black, Red, Green, Blue, Yellow, Magenta, or Cyan. The default setting is Auto.
<b>Background Color</b>	Sets the background color used for rendering (drawing) closed captions. The default setting is Auto. Available options include: Auto, White, Black, Red, Green, Blue, Yellow, Magenta, or Cyan.
<b>Background Opacity</b>	Sets the background opacity used for rendering (drawing) closed captions. The default setting is Auto. Available options include: Auto, Transparent, Translucent, Solid, or Flashing.
<b>Settings</b>	Sets the default settings for closed captions (Auto) or restores the settings you had previously configured (User) allowing you to easily change the closed caption settings between their default settings and your customized settings. The default setting is Auto. Available options include: Auto or User.
<b>Return To Main Menu</b>	Returns you to the User Settings Menu main screen.
<b>Restore Default CC Settings</b>	To reset all of the Additional Closed Caption settings to their default values, navigate to this option and press the ► key.



## Subtitle and DVS Settings Screen

The Subtitle and DVS Settings menu customizes the language and appearance of subtitles and turns the descriptive video service feature on and off on the DCX3510-M. Subtitles allow a viewer to watch television programs and movies that contain dialogue that is not in the viewer's native language. Subtitles are not included with many television programs (unlike closed captions).

A descriptive video service (DVS) is a special secondary audio track which is included with many television programs and is intended to assist the visually impaired. The DVS audio track provides a verbal description of each scene along with the program's normal dialogue.

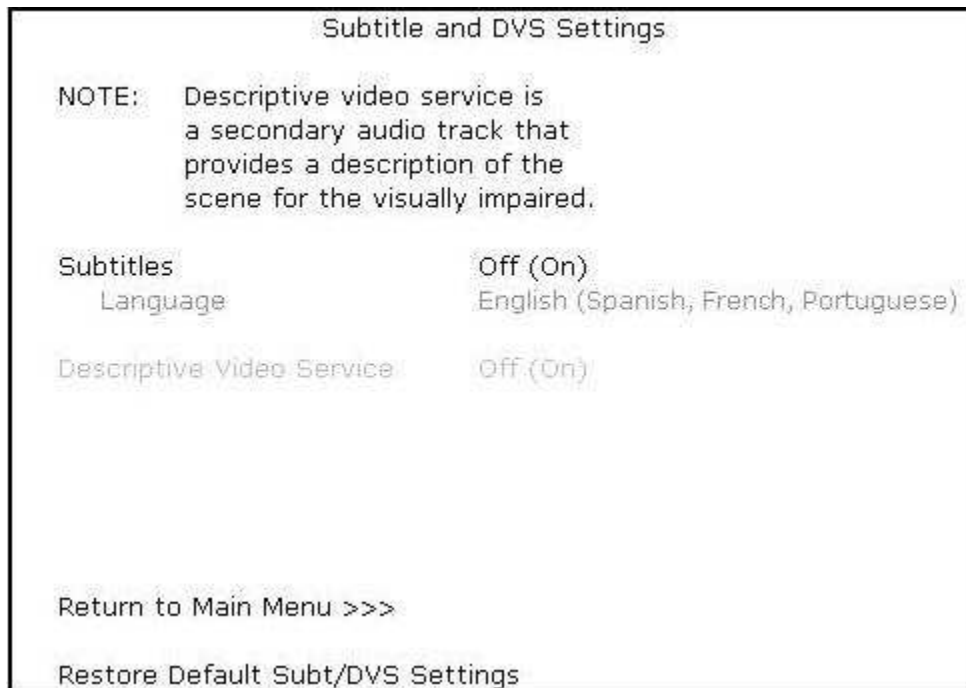

**Figure 17: Subtitle and DVS Settings Menu Screen**

**Table 5: Subtitle and DVS Settings Field Definitions**

Setting	Description
<b>Subtitles</b>	<p>The default setting is <b>Off</b>.</p> <ul style="list-style-type: none"> <li>• <b>Off</b>—Subtitles are not rendered (drawn) by the DCX3510-M.</li> <li>• <b>On</b>—Subtitles are rendered (drawn) by the DCX3510-M if they are included in the program and in the language specified by the Language setting.</li> </ul> <p>When the Subtitles option is set to On, Language can be selected from the menu.</p>
<b>Language</b>	<p>The Language setting is only available when the Subtitles option is set to On. Otherwise, this setting is disabled and can't be selected in the menu.</p> <p>The default language selection is <b>English</b>.</p> <ul style="list-style-type: none"> <li>• <b>English</b>—Renders (draws) subtitles in English if they are included in the program.</li> <li>• <b>Spanish</b>—Renders (draws) subtitles in Spanish if they are included in the program.</li> <li>• <b>French</b>—Renders (draws) subtitles in French if they are included in the program.</li> <li>• <b>Portuguese</b>—Renders (draws) subtitles in Portuguese if they are included in the program.</li> </ul> <p><i>Note: The DCX3510-M is not capable of translating subtitles from one language to another. For example, if French subtitles are included with the program, the DCX3510-M cannot translate them to into Portuguese if the Language option has been set to Portuguese. The DCX3510-M can only display subtitles in the language(s) that have been included within the program.</i></p>
<b>Descriptive Video Service</b>	<p>The default setting is Off.</p> <ul style="list-style-type: none"> <li>• <b>Off</b>—The DVS audio track is not played by the DCX3510-M.</li> <li>• <b>On</b>—The DVS audio track is played by the DCX3510-M if it is included in the program.</li> </ul> <p><i>Note: If the DVS setting is disabled and can't be selected from the menu, the software installed on the DCX3510-M can't support the DVS feature.</i></p>
<b>Return To Main Menu</b>	Returns you to the User Settings Menu main screen.
<b>Restore Default Subt/DVS Settings</b>	To reset all of the Subtitle and DVS settings to their default values, navigate to this option and press the ► key.

## Advanced Audio/Video Settings Screen

The Advanced Audio/Video Settings menu customizes several advanced audio and video features of the DCX3510-M, most notably the Dolby Volume feature and the Video Sharpness feature.

The Dolby Volume feature provides volume normalization across channels, programs, and commercials. Normalization is a process that adjusts the different volume levels across channels, programs, and commercials to the same approximate output volume. As a result,

sudden volume changes are reduced and the overall volume output of the DCX3510-M is more consistent.

The Video Sharpness feature softens or sharpens Standard Definition (SD) programs when viewed on either the HDMI or Component Video (YPbPr) outputs. When SD programs are viewed on a large screen television, picture quality can suffer because noise and other imperfections in the picture can be magnified on the large display. The Video Sharpness feature is used to soften the picture and reduce the appearance of these imperfections.

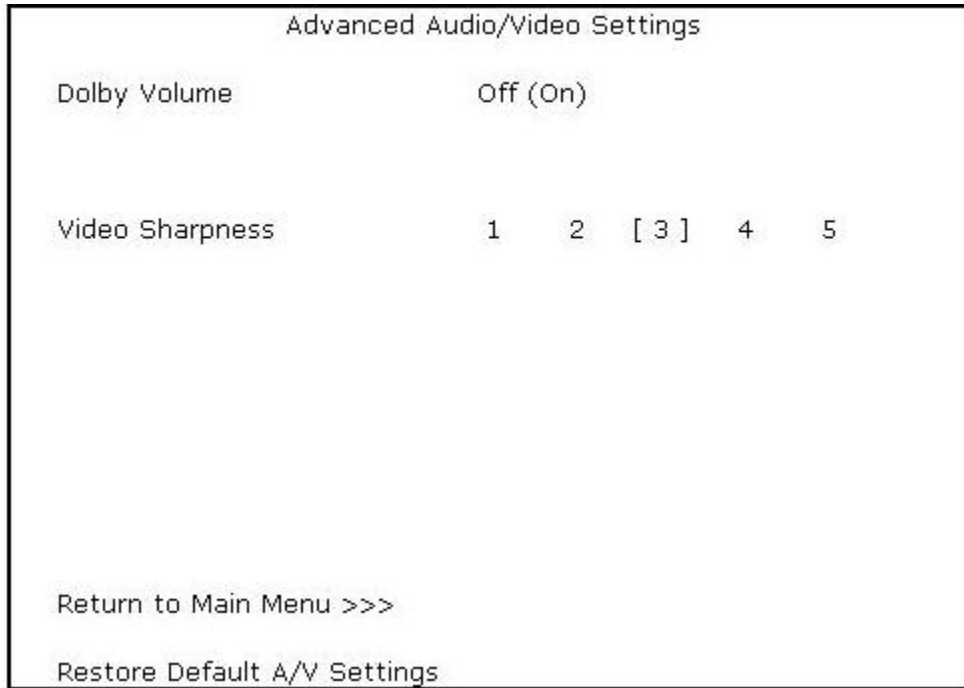

**Figure 18: Advanced Audio/Video Settings Menu Screen**

**Table 6: Advanced Audio/Video Settings Field Definitions**

Setting	Description
<b>Dolby Volume</b>	<p>The default setting is Off.</p> <ul style="list-style-type: none"> <li>• <b>Off</b>—Output volume may fluctuate during commercials or when changing channels.</li> <li>• <b>On</b>—Maintains a more consistent output volume regardless of the channel or program being viewed.</li> </ul>
<b>Video Sharpness</b>	<p>The Video Sharpness setting allows you to adjust the picture sharpness when viewing a standard definition (SD) program on the DCX3510-M.</p> <p>The Video Sharpness setting affects the HDMI and Component Video (YPbPr) outputs .Level of 3 is the default value.</p> <p>The DCX3510-M supports five distinct levels of analog video picture sharpness. A value of 1 corresponds to a “softer” picture while a value of 5 corresponds to a “sharper” picture.</p> <p>The best sharpness setting depends upon the video connection being used, the display quality of the TV, and your own personal preference.</p>
<b>Return To Main Menu</b>	Returns you to the User Settings Menu main screen.
<b>Restore Default A/V Settings</b>	To reset all of the Advanced Audio/Video settings to their default values, navigate to this option and press the ► key.

# 7

## Troubleshooting

Before calling your service provider, review this troubleshooting guide. This information is to help you quickly solve a problem. If your problem still exists, contact your service provider.

Problem	Possible Solution
The DCX set-top will not power on	<ul style="list-style-type: none"> <li>• The DCX set-top has received a software update and may not power on while the new software is being installed. Try again in a few minutes.</li> <li>• Verify that the AC power cord of the external power supply is connected to the DCX set-top and an AC outlet. Unplug the DCX set-top from the AC outlet, plug it back in, and then press the POWER button.</li> <li>• If the DCX set-top is connected to a switched outlet on another unit, verify that that unit is powered on. Unplug the power cord from the DCX set-top's AC outlet, plug it back in, and then press the POWER button. Use an unswitched outlet, if possible.</li> <li>• Press the POWER button on the DCX set-top front panel instead of the remote control. The batteries in the remote control may be depleted.</li> </ul>
The remote control does not work	<ul style="list-style-type: none"> <li>• Verify that the remote control is in "Cable" mode.</li> <li>• Verify that there are no obstructions between the remote control and the DCX set-top. Aim the remote control directly at the DCX set-top front panel, not the TV or VCR.</li> <li>• The angle between the remote control and the DCX set-top may be too large. Stand in front of the DCX set-top and not too far to either side.</li> <li>• Press and release operation keys one at a time, firmly and deliberately.</li> <li>• Check the batteries in the remote control. Install new batteries if needed.</li> </ul>
There is no audio when viewing cable channels	<ul style="list-style-type: none"> <li>• Verify that the mute button on the remote control has not been pressed. Press mute on the remote control to restore sound.</li> <li>• If the DCX set-top audio output is connected to the TV, verify that the mute button on the TV has not been pressed.</li> <li>• If the DCX set-top audio output is connected to a home theater receiver, verify that the receiver is set to the appropriate input source and the mute button on the receiver has not been pressed.</li> <li>• Verify that you have the correct cables for the audio connections.</li> <li>• Verify that the audio cables are firmly connected between the DCX set-top and the audio playback device (TV, receiver, DVD player, etc.).</li> </ul>
There is no audio from the center and/or surround speakers of a home theater receiver connected to the DCX set-top	<p>Not all programs feature full Dolby Digital [5.1] or Dolby Digital Plus [7.1] surround sound. In some cases, the programs may only contain left and right stereo audio.</p> <ul style="list-style-type: none"> <li>• Verify that the S/PDIF cable (optical) is firmly connected to the DCX set-top and the home theater receiver.</li> <li>• Verify that the home theater receiver is set to a surround sound audio mode (Dolby Pro Logic®, Dolby Pro Logic II®, Dolby Pro Logic IIx®).</li> <li>• Verify that the receiver is properly configured to work with all connected speakers.</li> </ul>

Problem	Possible Solution
<p>There is no video on the TV screen</p>	<ul style="list-style-type: none"> <li>• Verify that the TV is powered on and set to the appropriate input source for the DCX set-top.</li> <li>• Verify that the DCX set-top is powered on and tuned to an authorized cable channel.</li> <li>• Verify that all video cables between the DCX set-top and the TV are firmly connected.</li> <li>• Verify that the coaxial cable feed is firmly connected to the DCX set-top and the wall jack.</li> <li>• If the DCX set-top video output is connected to a home theater unit, verify that the home theater unit is powered on and set to the appropriate input source.</li> <li>• If the DCX set-top video output is connected to a TV through an HDMI connection, power off the TV and then power off the DCX set-top. Wait one second and then power on the devices.</li> <li>• Not all HDTVs can display every output format (1080p60, 1080p30, 1080p24, 1080i, 720p, 480p, or 480i) available on the DCX set-top. To select a different format:             <ol style="list-style-type: none"> <li>1. Ensure that your DCX set-top is plugged into a power outlet and is turned off.</li> <li>2. Press the MENU key on the remote control. Your settings are displayed on the DCX set-top front panel display.</li> <li>3. Press the ▲ and ▼ keys to display the HDMI/YPbPr OUTPUT setting.</li> <li>4. Press the ► key to cycle through the available output formats until a picture displays on the TV.</li> </ol> </li> </ul>
<p>No graphics or program guides appear on the TV screen</p>	<p>If you use the IEEE-1394 connection, on-screen graphics, including closed captions and program guides, are not displayed by the DCX set-top. On-screen graphics and captions may still be overlaid by your TV, if enabled. Alternatively, use HDMI or component video instead.</p>
<p>No closed captions display</p>	<ul style="list-style-type: none"> <li>• Verify on the User Settings menu that closed captions are enabled on the DCX set-top.</li> <li>• Verify that closed captions are enabled on the TV.</li> </ul> <p><i>Note: Closed captioning may not be available on the current program.</i></p>
<p>There are black bars to the right and left of the picture</p>	<p>Wide screen TVs display 4:3 programs in this format unless set to Stretch. Turn on the 4:3 OVERRIDE feature in the User Settings menu. This enables most wide screen TVs to stretch the video to fill the screen (see your TV manual for information about stretching 4:3 video).</p> <ul style="list-style-type: none"> <li>• If the DCX set-top is connected to a wide screen TV, verify that the TV TYPE is set to 16:9 in the User Settings menu.</li> </ul> <p>Many HD programs are broadcast in pillar-box format with black bars to the left and right of the picture. These programs are broadcast in 16:9 HD formats even though the video is not 16:9.</p>

Problem	Possible Solution
<p>There are black bars above and below the picture</p>	<p>All 4:3 HDTVs display HD programs in letterbox format (black bars above and below the picture) because of the shape of the display screen.</p> <ul style="list-style-type: none"> <li>• Turn on the 4:3 OVERRIDE feature in the User Settings menu. This enables most standard screen TVs to display a full screen picture when the DCX set-top is tuned to a 4:3 program.</li> <li>• Set the TV TYPE to 4:3 Pan-Scan. This enables the DCX set-top to remove the black bars above and below the picture when possible.</li> </ul> <p>Some SD programs are broadcast in the letterbox format with black bars above and below the picture. Some widescreen TVs offer a zoom feature that may be able to remove the black bars (see your TV manual for information about zooming 4:3 video).</p>
<p>There are black bars on all four sides of the picture</p>	<p>This may occur on a 4:3 TV if the 4:3 OVERRIDE setting is OFF. To set 4:3 SD programming to fill the screen, depending on the capabilities of the TV, set 4:3 OVERRIDE to 480i or 480p.</p> <p>This may occur on a 16:9 TV if the active video for an SD broadcast is in letterbox format. To confirm, wait for a commercial or look for a graphic, such as a network logo. If the commercial fills the screen from top to bottom, or the graphic appears below the active video, the program is being letterboxed by the broadcaster. You can minimize this by activating the zoom feature on the TV.</p> <p>A broadcaster may include black bars on either side of a wide screen broadcast. This is called a "hybrid" aspect ratio and results in a black border surrounding the video on a 4:3 TV. Because this is part of the broadcast, the DCX set-top cannot correct the video. You may be able to minimize the border using the zoom feature on the TV.</p>
<p>Colors do not appear correctly</p>	<p>Be sure to match up each signal to the same YPbPr connection on the TV, otherwise the colors will not appear correctly on your TV.</p>



ARRIS Enterprises, Inc.  
3871 Lakefield Drive, Suwanee, GA 30024 [www.arris.com](http://www.arris.com)

365-095-25384 x.1 01/14

